

# METAL SEATED PLUG VALVE

**SIZES: 3" - 108"**



# SERIES 4800 METAL SEATED PLUG VALVE DESIGN FEATURES

**CUTS THROUGH DEBRIS & SOLIDS!**  
**CERTIFIED: ANSI/NSF-61 AND ANSI/NSF-372**



**PATENT PENDING**



## **OTHER PLUG VALVES**

J&S precisely machines metal seats providing zero-leakage.

The J&S plug valve has no rubber that can be damaged like traditional rubber seated plugs.

## **BODY, BONNET, & DISC**

Ductile Iron ASTM A536-65-45-12

## **BODY SEAT RING**

Nitronic 60 Non-Galling Stainless Steel  
Retained with 316 Stainless Steel Bolts

## **PLUG SEAT RING**

Type 316 Stainless Steel  
Sharpened to a Hatchet-like Blade  
Cuts through Debris  
Retained with 316 Stainless Steel Bolts

## **FIELD ADJUSTABLE & REPLACEABLE SEATS!**

## **DOUBLE OFF-SET SEAT**

Design will not Allow Seats to Make Contact  
Until 95% Closure to Prevent Wear

## **FULL ROUND PORT**

Creates Less Turbulence, Less Head-Loss,  
passes Larger Solids Round Ported Plug Valves  
Allow More Effective Pipeline Pigging than  
Rectangular Port Plug Valves

## **VELOCITY**

Able to Handle 30 Ft./Sec. Velocity and  
Large Pressure Drop Across the Valve

## **FLANGE PRESSURE CLASS**

ASME B16.1 Class 125;  
Rated for 250psi Working Pressure  
ASME B16.1 Class 250;  
Rated for 350psi Working Pressure

## **COATING**

Fusion Bonded Epoxy Coated,  
Inside & Outside, per AWWA C550

## **ZERO LEAKAGE**



**WATER QUALITY  
ANSI/NSF 61  
ANSI/NSF 372**

Design and Materials Subject to Change Without Notice. Call for Verification and Any Updated Drawings

# INSTALLATION DIMENSIONS

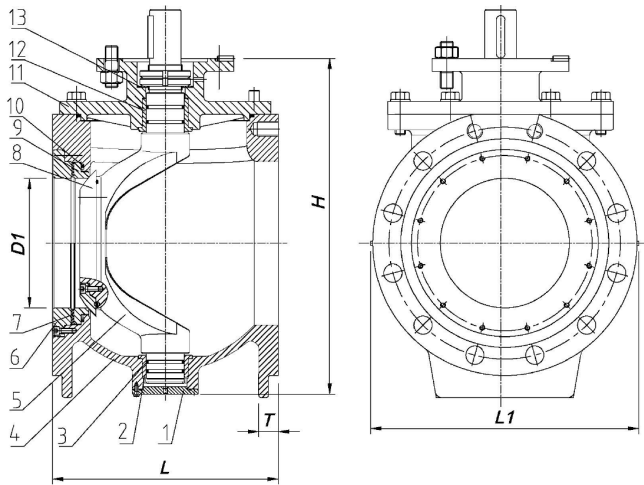

**3"-30" PLUG VALVE**

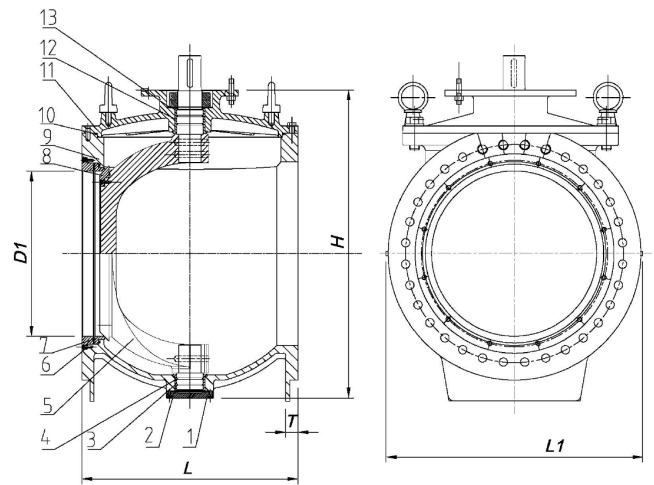

**36" AND LARGER PLUG VALVE**

## FEATURES

- Ductile Iron Body, Bonnet, and Plug
- 316 Stainless Steel Plug Seat
- Nitronic 60 Stainless Steel Seat Ring
- Stainless Steel Bolt, Washer, and Nut
- Low Operating Torque
- Low Friction Streamlined Plug Design
- Fusion Bonded Epoxy Coating In and Out
- Class 125 or 250 Flange
- ANSI/NSF 61 and ANSI/NSF 372 Certified

No.	PART NAME	MATERIALS
1	Button Cap	Ductile Iron ASTM A536 65-45-12
2	Lower Bushing	Bronze
3	O-Ring	EPDM
4	Body	Ductile Iron ASTM A536 65-45-12
5	Plug	Ductile Iron ASTM A536 65-45-12
6	Compression Ring	Ductile Iron ASTM A536 65-45-12
7	Washer	EPDM
8	Plug Trim	Stainless Steel ASTM A276 S31600
9	Seat	Nitronic 60 (S21800)
10	O-Ring	EPDM
11	Bonnet	Ductile Iron ASTM A536 65-45-12
12	Upper Bushing	Bronze
13	Washer	Brass ASTM B16

## DIMENSIONS

SIZE	3"	4"	6"	8"	10"	12"	16"	18"	20"	24"	30"	36"	42"	48"	54"	60"
MODEL	4803	4804	4806	4808	4810	4812	4816	4818	4820	4824	4830	4836	4842	4848	4854	4860
L	8"	9 1/2"	11 1/4"	12 1/4"	13 3/4"	15 1/8"	21 1/2"	21 3/4"	24 7/8"	28 5/8"	35 1/2"	41 3/4"	46 1/8"	50 1/2"	61 3/4"	72 3/4"
L1	7 7/8"	9 5/8"	11 1/2"	13 3/4"	16"	19 5/8"	24"	25 1/2"	28 3/4"	35 3/4"	45 1/4"	52 3/4"	59 3/4"	66 1/4"	80 1/4"	92 7/8"
H	12 1/4"	13 1/8"	15 3/8"	19 1/2"	23 1/4"	26 1/8"	33 5/8"	36"	39 3/4"	46 3/4"	56 1/2"	66"	75 5/8"	84 5/8"	98"	113 7/8"
D1	2 3/8"	3"	4 1/2"	6 1/4"	8 1/4"	9 1/2"	12 5/8"	14 1/4"	16 3/8"	18 7/8"	25 1/4"	31 7/8"	36 5/8"	39 7/8"	48 3/8"	56 1/4"
T	3/4"	1"	1"	1 1/8"	1 1/4"	1 1/4"	1 1/2"	1 1/2"	1 3/4"	1 7/8"	2 1/8"	2 3/8"	2 5/8"	2 3/4"	3"	3 1/8"

Larger Sizes Available. Design and Materials Subject to Change Without Notice. Call for Verification and Any Updated Drawings

# METAL SEATED PLUG VALVE SPECIFICATIONS

## 1. SCOPE

**1.01** This specification covers the design, manufacture, and testing of 3-inch through 108-inch ductile iron Metal Seated Eccentric Plug Valves suitable for water, wastewater, storm water, and raw water service with pressures up to 350psi.

## 2. STANDARDS

**2.01** Valves shall be designed, manufactured and tested where applicable in accordance with American Water Works Association Standard (AWWA) C517, and shall be ANSI/NSF 61 and ANSI/NSF 372 Certified for use in drinking water.

**2.02** Valves shall be hydrostatically pressure tested where applicable in accordance with American Water Works Association Standard AWWA C517.

## 3. CONNECTIONS

**3.01** Valves shall have flange end-connections in compliance with ANSI B16.1, Class 125, rated for 250psi or Class 250 rated for 350psi working pressure.

## 4. DESIGN

**4.01** Valves shall be quarter-turn, non-lubricated, eccentric type with Nitronic 60 to 316 Stainless Steel seating.

**4.02** Valve shall have a round port to reduce turbulence through the valve and allow effective pigging of the pipeline.

**4.03** Valves, 30-inch and smaller, shall have one piece with a 316 Stainless Steel Seat Ring sharpened to cut through debris.

**4.04** Valves, 36-inch and larger, shall have 2-piece sub-shaft connected to the closure member with a 316 Stainless Steel Seat Ring sharpened to cut through debris.

**4.05** Valve shall be capable of 30 feet/second velocity and can handle large pressure drop across the valve without cavitation damage.

**4.06** Valve closure member shall have a mechanically retained and replaceable seat ring providing zero-leakage during forward flow.

**4.07** Valve shaft seals shall consist of 2 o-rings located on the stem in the upper and lower journal area.

**4.08** Valve seat shall be field adjustable and replaceable without removing the valve from the line.

**4.09** Valve radial shaft bearings shall be supplied in the upper and lower bearing journals

**4.10** Valve shall be permanently lubricated.

**4.11** Valve thrust bearings shall be provided in the upper and lower journal areas.

## 5. MATERIALS

**5.01** Valve body and cover shall be constructed of ASTM A536 65-45-12 ductile iron.

**5.02** Valve body seat shall be Nitronic 60 mechanically retained to the body.

**5.03** Valves, 30-inch and smaller, closure members shall be ductile iron ASTM A536 65-45-12 with a 316 Stainless Steel seat ring.

**5.04** Valve mechanically retained seats shall have Nylock Stainless Steel bolts.

**5.05** Valve cover bolting shall be Series 300 Stainless Steel.

## 6. COATINGS

**6.01** Valve shall be coated inside and out with NSF-61 Certified Fusion Bonded Epoxy Coating or NSF-61 Certified 2-Part Thermal Setting Epoxy Paint.

**6.03** Valve internal and external coatings shall be in accordance with AWWA C550.

## 7. ACTUATION

**7.01** Valves 3-inch and larger valves shall include a totally enclosed and sealed worm gear actuator.

**7.02** Valve gear actuators shall be designed to withstand, without damage, a rim-pull of 200 lb. on the handwheel or an input torque of 300 ft-lbs. for nuts.

**7.03** Valves for buried service actuators shall be packed with grease and sealed.

**7.04** Valve shall be adapted to allow Electric, Hydraulic, Pneumatic, or Electro-Hydraulic Actuators to become integrated with the control system or operated automatically.

## 8. OPTIONS

**8.01** Extension Stems

**8.02** Indicator Posts.

**8.03** Valve Boxes

**8.04** Indicator Posts

**8.05** Electric Motor Operators

**8.06** Limit Switches

## 9. MANUFACTURER

**9.01** Manufacturer shall demonstrate a minimum of 5-years of experience in the manufacture of like valves..

**9.02** Metal Seated Eccentric Plug Valve, Series 4800, manufactured by J&S Valve, Inc. Huffman, TX, USA or preapproved equal. (06020202 jb sb rl)



2323 1st Street Huffman, Texas 77336

T: 281.324.3990 | F: 281.324.6879

E: Sales@jandsvalve.com