

8000 SERIES

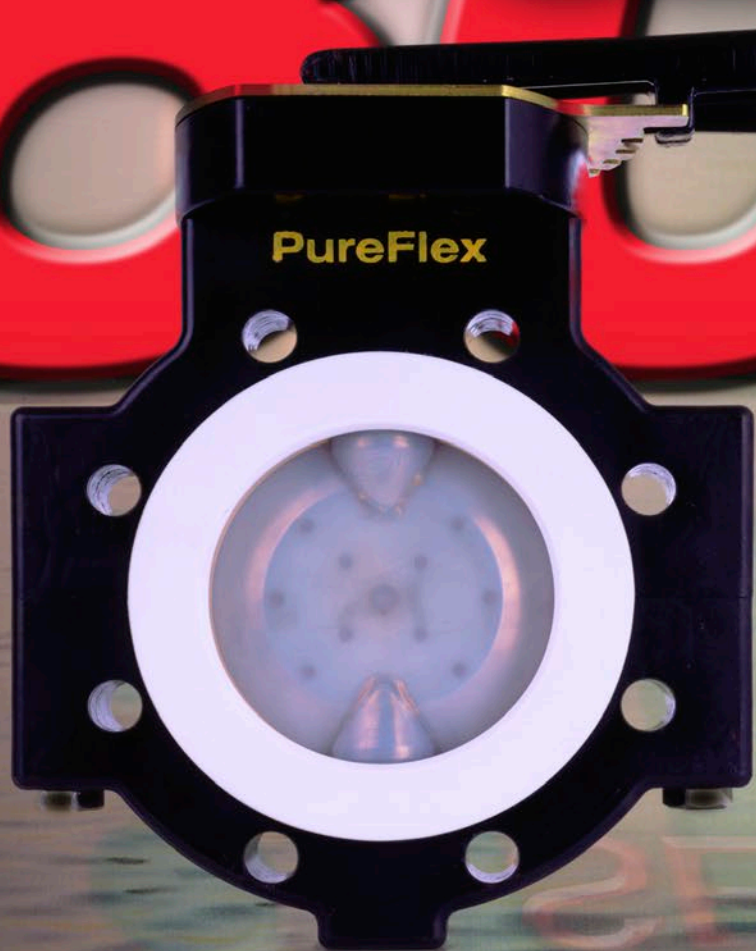

PureFlex



PureFlex

PureFlex[®]
an ANDRONACO INDUSTRIES company

PUREFLEX



PureFlex is a world leading manufacturer of high performance Fluoropolymer and Composite products and technologies. We specialize in the manufacturing of fluid handling and sealing products specifically designed for Chemical, Pharmaceutical and Ultra-Pure related industries.

Since 1994, we have earned a reputation for creating fluid handling and sealing products that are truly different. We create innovation -- Products that serve demanding applications better than before. PureFlex excels in its service, aggressive in its technology, bold in vision, and responsible in its regard for safe and dependable products.



800 Series Butterfly Valve

The 800 series fully lined composite valve is manufactured to be corrosion resistant inside and out in hostile services. The valve has the strength of steel with 1/2 the weight and is 10x more impact resistant than standard FRP. 800 Series valves have the purity required for Ultra-Pure applications and are used for shut-off and throttling of most known corrosive fluids. It can be used for end of the line service and is bubble tight at full rated pressure of 150 psi, has triple stem seals and can operate at temperatures of (-)60°F to (+)250°F.



COMPOSITE VALVE BODY DURCOR®

The 800 series valve body is manufactured from Durcor®, PureFlex proprietary advanced fiber reinforce composite. Durcor reinforcing fibers are long and interlocked, this interlocked reinforcement system transfers loads throughout the fiber matrix, making the 800 series valve body virtually indestructible. It has tensile and compressive strength that rivals steel, along with outstanding impact resistance that is unmatched in the industry. The strength of Durcor enables the 800 series valve to maintain ASME face to face dimensions, be direct threaded for lug design and allows it to be installed in any type of piping system without the need for special considerations. Durcor excels in temperatures from (-)60°F to (+)250°F and has only .001" of thermal expansion across its full temperature range.

- Tensile strength of 50,000 psi per ASTM D-638 or 345 Mpa
- Notched Izod impact strength of 35 ft-lb/in per ASTM D-256 or 1868 J/M are achieved.

Tensile strength comparison

Steel 60,000 psi

Durcor® 50,000 psi

FRP 12,000 psi

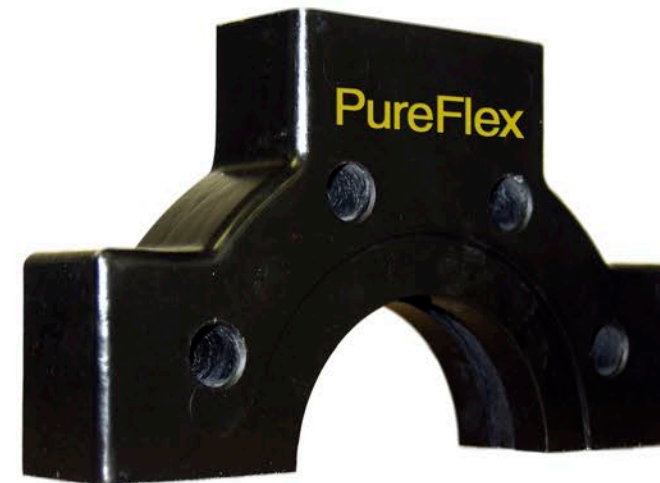

Durcor vinyl ester backbone provides excellent protection when exposed to aggressive chemicals and hostile atmospheres such as acid sprays, bleach, salt water and high chlorides. The 800 series valve body out-performs ductile iron valves not only in corrosive environments but non corrosive as well. Its lightweight advantage reduces the need for heavier support structures for hanging, eliminates the need for extra equipment and personnel for valve installation and reduces pipe strain once installed. The 800 series valve body is so dependable and maintenance free that we offer the industries first 5 year warranty against failure. Contact PureFlex or your local distributor for details.



THE 800 SERIES VALVE BODY EASILY WITHSTANDS THE IMPACT OF A GUNSHOT

**The strongest, lightest,
most chemically resistant
valve in the world**

800 VALVE FEATURES

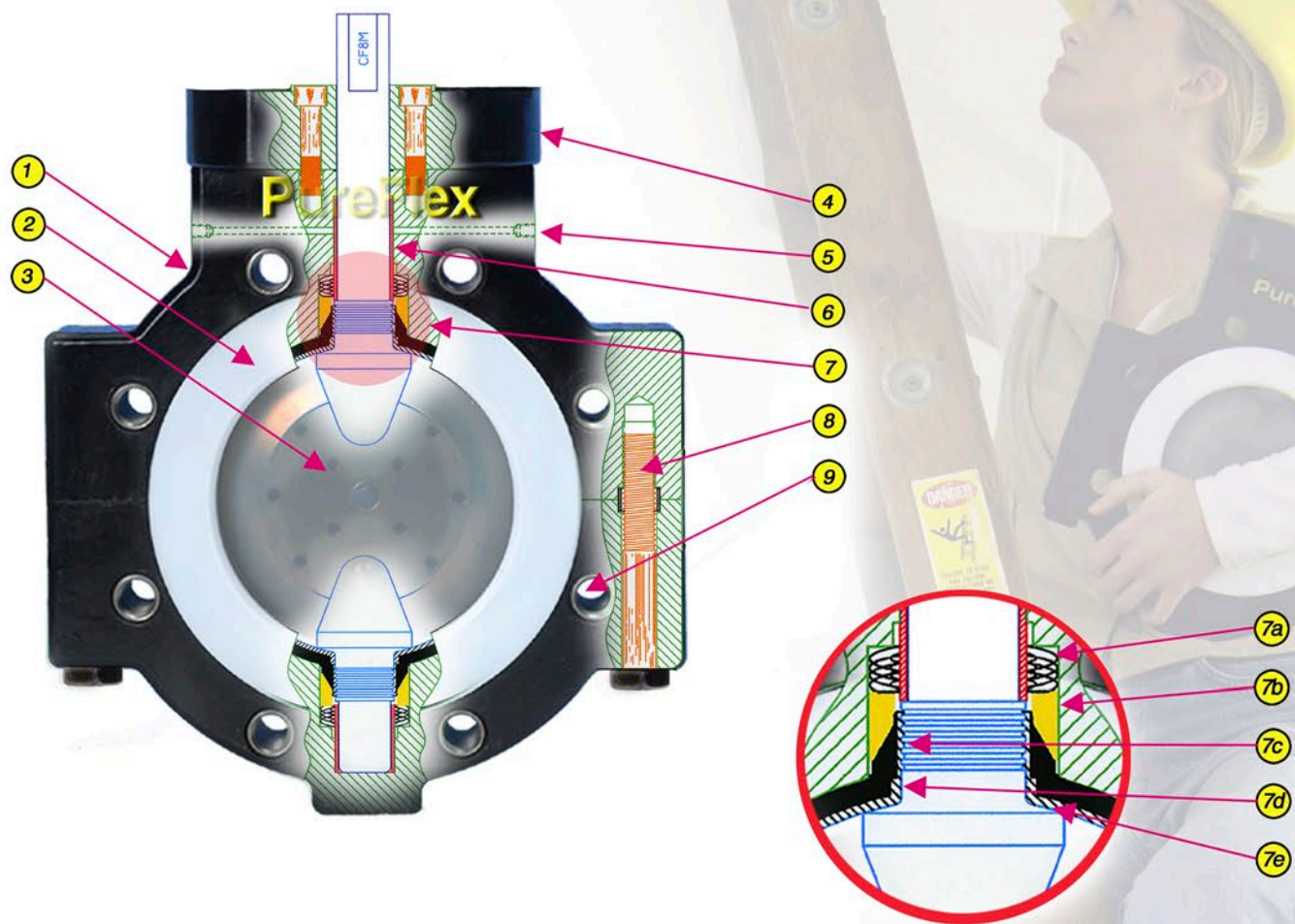

- 1 Composite Durcor® valve body is light weight, provides maximum external corrosion protection, tensile and impact resistance.
- 2 PTFE seat is .125" nominal thickness and is recessed into body, seat is energized by one piece non-wetted elastomer providing bubble tight sealing.
- 3 One piece PFA lined Ductile iron Disc & Stem provides high Cv value, blow-out protection and has a double "D" shaft drive, can be lined with PFA or UHMWPE.
- 4 Mounting Flange is ISO 5211 compliant.

- 5 NPT connections (optional) for purge or leak detection, inert gas pad or sealing lubricant port.
- 6 PTFE composite bearing (top & bottom) is self-lubricating, reduces friction and is maintenance free. Triple stem seals top and bottom.
- 7a 304 S.S. coil springs keep preload on stem seal and taper ring.
- 7b 304 S.S. tapered ring compresses energized PTFE liner onto locking barbs, creates tortuous no leak path.
- 7c Locking barbs molded or machined onto disc stem.

- 7d Stem seal is created through an interference fit as the stem is passed through the body liner.
- 7e Primary seal is achieved at the disc hub and liner (ball & socket) through preloaded force.
- 8 Bottom PTFE coated B7 standard. Other materials available.
- 9 Flanged Wafer or Lug design with composite threads 250ft. pound pull - out strength. Alloy inserts also available.

LINERS & DISCS

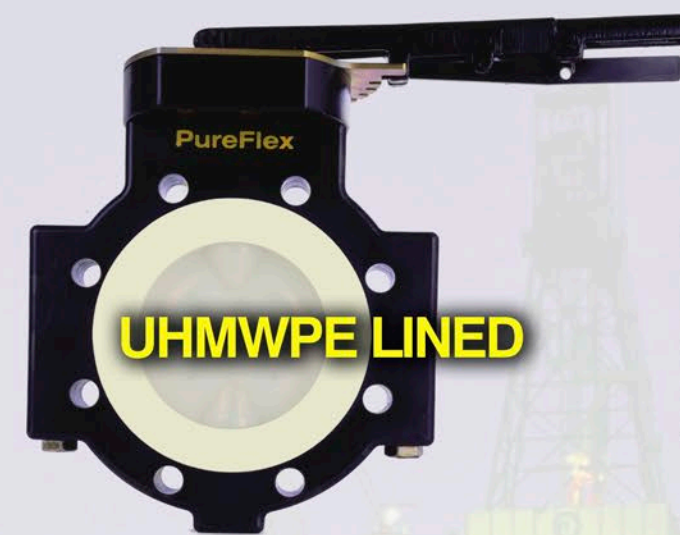

MAXIMUM ABRASION RESISTANCE AGAINST EROSIVE SERVICES

Ultra High Molecular Weight Polyethylene is a tough abrasion resistant polymer perfectly suited for severe erosive services while providing good chemical resistance. UHMWPE will consistently outperform rubber lined or plastic valves in fluids containing abrasive particles with or without corrosive media present at temperatures of (-)20°F to +200°F. PureFlex 800 series valves with UHMWPE are 1/2 the weight of metal lined valves and provide outstanding service life in Pulp and Paper processing, mining and metal refining, power plants, pollution abatement and chemical industries. Typical services include:

- Fly Ash
- Lime Slurry
- Lime Mud
- Green Liquor
- White Liquor
- Zinc Sulfate Slurry
- Iron Ore Tailings
- Titanium Dioxide Slurry
- Sodium Chloride Brine

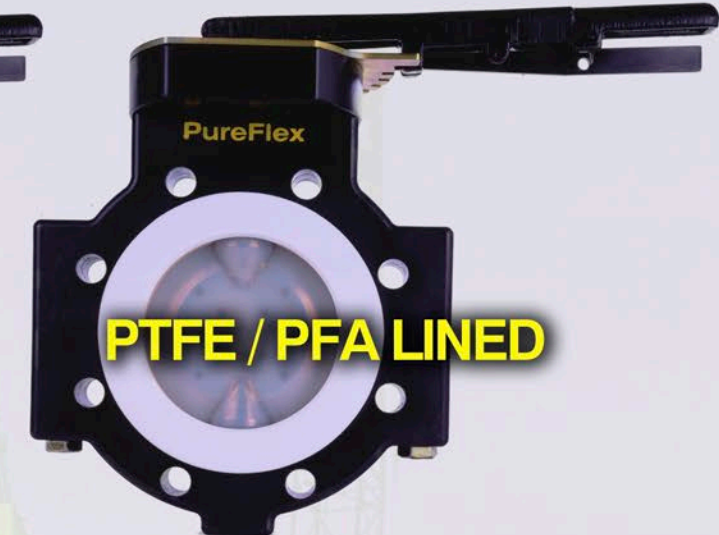

MAXIMUM CHEMICAL RESISTANCE AGAINST CORROSIVE SERVICES

PTFE (Polytetrafluoroethylene) and PFA (Perfluoroalkoxy) are fluoropolymers that provide outstanding chemical and temperature resistance from (-)60°F to +250°F. The fluoropolymers non-stick properties aid to eliminate build-up of deposits on valve seat and disc that could possibly affect valve performance. PureFlex 800 series valves lined with PTFE / PFA are unequalled for severe chemical services and will resist the attacks of:

- All Acids
- All Solvents
- All Bleach solutions
- All Caustics
- All Peroxides
- All Phenols
- All Organic Chlorides & Sulfates
- All Inorganic Chlorides & Sulfates



Disc Options

- PFA lined Ductile Iron (STD.)
- 316 S.S.
- Hastelloy® C276
- Titanium Gr. C-2
- UHMWPE / 316 S.S.

TECHNICAL DATA

Cv Data

Valve Size	Full Open Cv
2"	112
3"	334
4"	570
6"	1415
8"	3110
10"	5223
12"	7944

Refer to chart

Cv at Disc Angle of Rotation

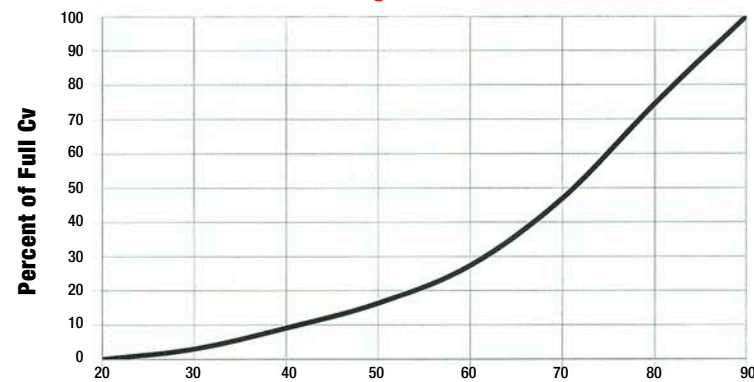

Sizing Torques - Clean, Clear Fluids

Valve Size	Max Differential Pressure	
	PTFE	UHMWPE
2"	275 in.-lbs.	405 in.-lbs.
3"	325 in.-lbs.	463 in.-lbs.
4"	570 in.-lbs.	2300 in.-lbs.
6"	1250 in.-lbs.	3660 in.-lbs.
8"	1660 in.-lbs.	4116 in.-lbs.
10"	3270 in.-lbs.	6915 in.-lbs.
12"	4175 in.-lbs.	8102 in.-lbs.

Note: For Slurries, add 35% to above values

Disc Rotation (Degrees)

Disc Position (Degrees)	Percent of Total Cv
20	0
30	3
40	9.1
50	16.3
60	27.4
70	47
80	74.5
90	100

Refer to chart above

MATERIALS

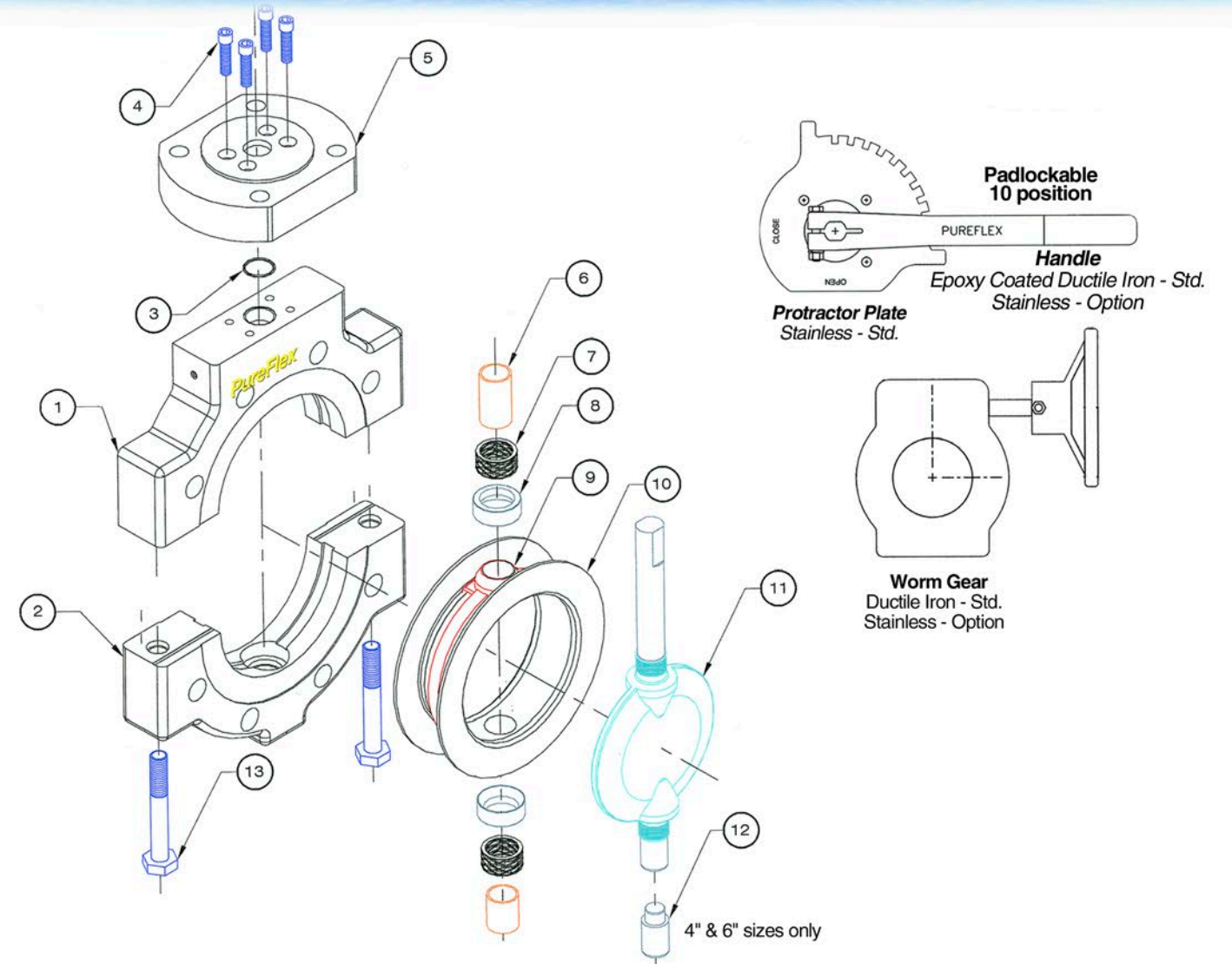

800 VALVE DATA

- Sizes:** 2" to 12" Flanged wafer & lug body (Larger sizes available - Consult factory)
- Pressure:** Full vacuum to 150psi
- Temperature Rating:** (-)60°F to (+)250°F
- Flow:** Bi-directional
- Conformance:** Conforms to all applicable standards API 609, DIN 3202, ISO 5752, and BS EN593
- Flange Adaptability:** ASME B16.5 class 150 drilling
ASME class B16.1 class 125
Other flange drillings are available (Consult factory for higher temperature ratings)

Pressure / Temperature

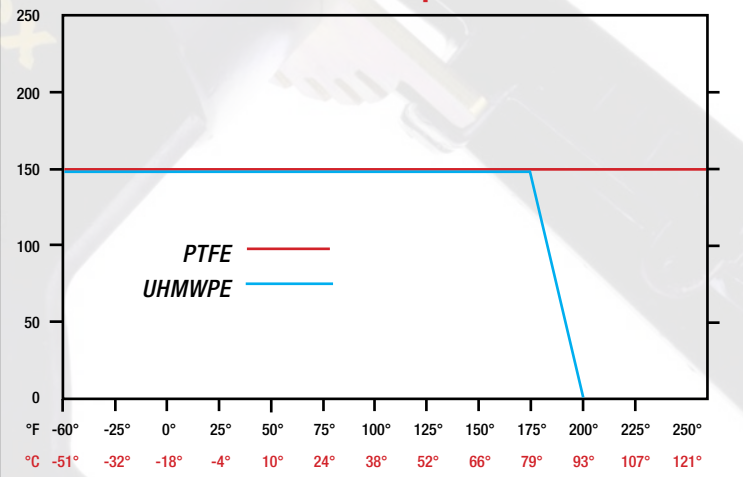

800 Series Valve Parts List

Item	Description	Standard Material	Qty.
1	Upper Body	Durcor®	1
2	Lower Body	Durcor®	1
3	Atmospheric Seal	Viton® (FKM)	1
4	Socket Head Cap Screw	Gr. B7 ASTM A193 - PTFE Coated	4
5	ISO Mounting Flange	Durcor®	1
6	Bearing	PTFE-Composite	2
7	Coil Spring	304 Stainless Steel	2
8	Taper Ring	304 Stainless Steel	2
9	Seat Energizer	Silicone	1
10	Seat	PTFE	1
11	Disc	PFA Lined Ductile Iron	1
12	Hex Head Cap Screw	Gr. B7 ASTM A193-PTFE Coated	2
13	Stem Extension (4" & 6" Sizes Only)	CF8M Stainless Steel	1

Valve Options

Item	Description
4	Gr. B840 ASTM A193 Stainless Steel
	Hastelloy C276 ASTM B574
9	Viton®
10	UHMWPE
	TFM / NXT PTFE
11	UHMWPE / Stainless Steel
	CF8M Stainless Steel
	CW6M (Hastelloy C276) ASTM A494
12	Titanium Gr. C-2 ASTM B367
	Gr. B840 ASTM A193 Stainless Steel
13	Hastelloy C276 ASTM B574
	CW6M (Hastelloy C276) ASTM A494
	Titanium Gr. C-2 ASTM B367

800 SERIES

DIMENSIONS & WEIGHTS

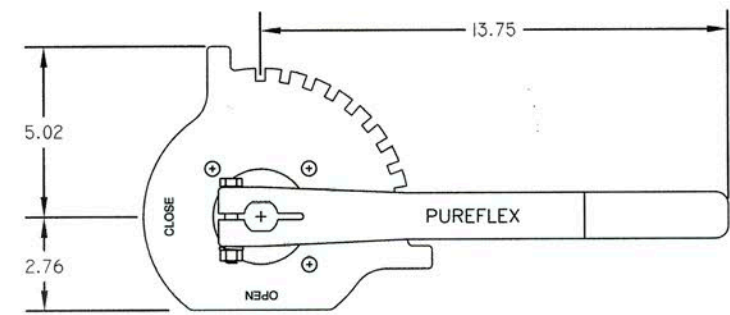
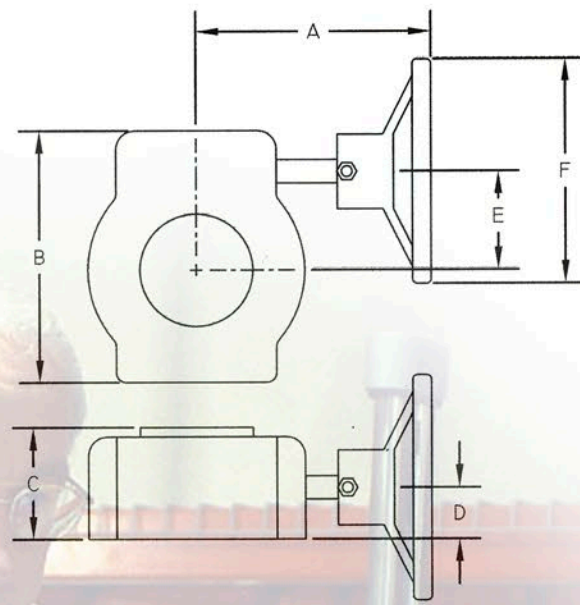
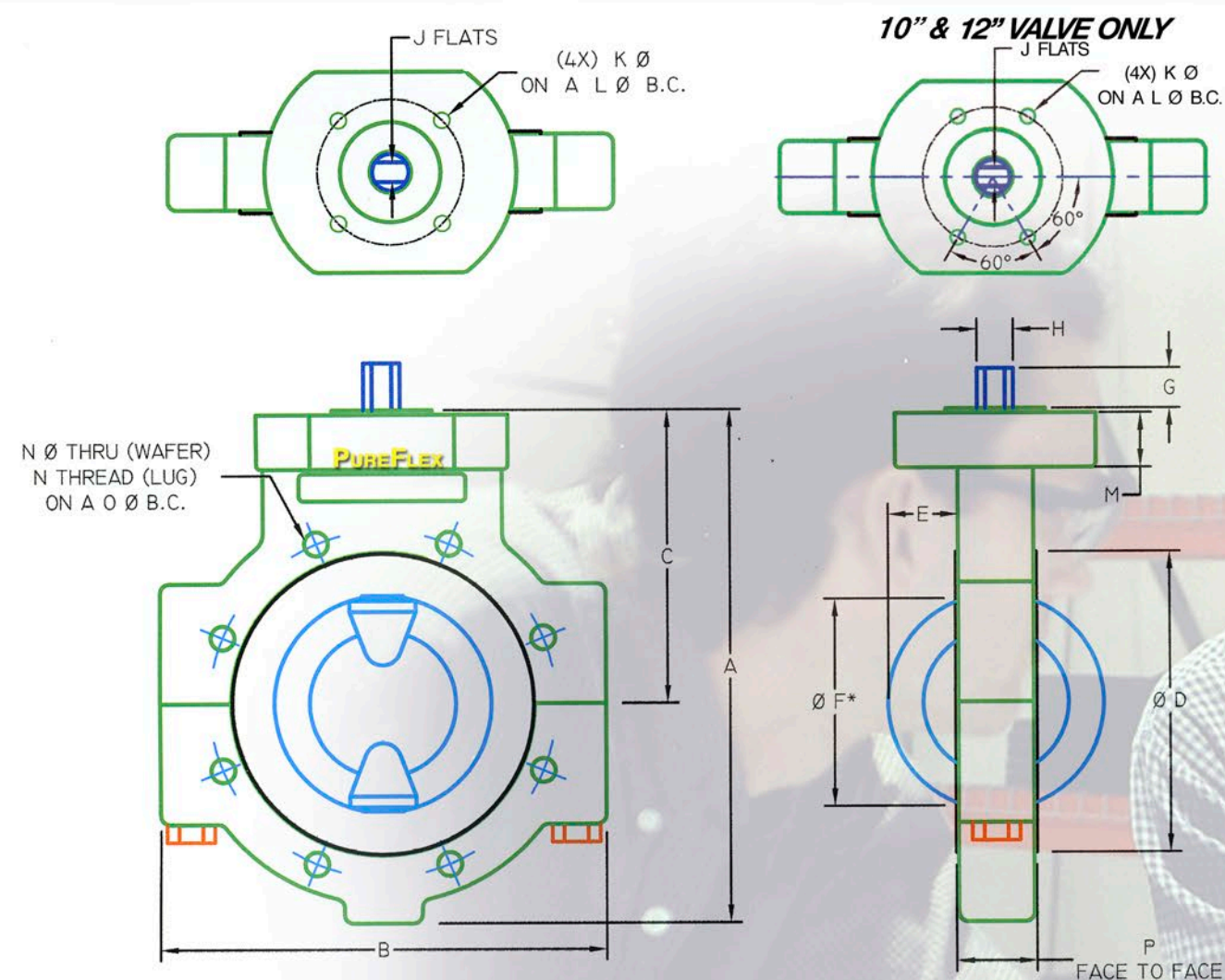

Wrench Assembly 2" - 6" Sizes

Wafer and Lug Valves with Gear						
SIZE in. (mm)	A in. (mm)	B in. (mm)	C in. (mm)	D in. (mm)	E in. (mm)	F in. (mm)
2 - 4 (50.8) (101.6)	6.250 (158.7)	5 (127)	2.578 (65.5)	1.109 (28.2)	2.063 (52.3)	6 (152.4)
6 - 8 (152.4) (203.2)	6.750 (171.4)	5 (127)	2.578 (65.5)	1.109 (28.2)	2.063 (52.3)	8 (203.2)
10 - 12 (254) (304.8)	7.250 (184.1)	6.719 (170.7)	2.984 (75.7)	1.375 (34.8)	2.500 (63.5)	12 (304.8)

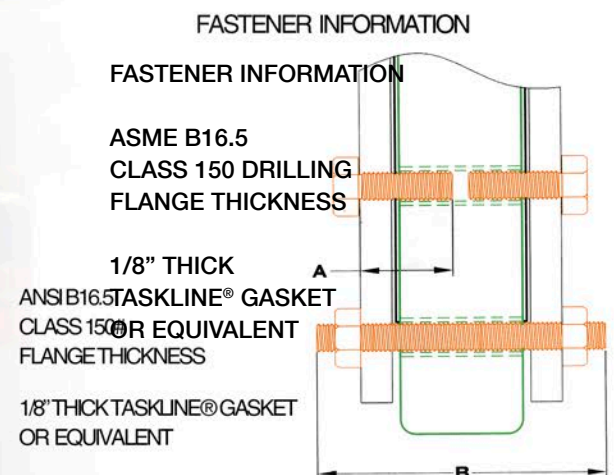

800 SERIES BUTTERFLY VALVE																	
Size in (mm)	A	B	C	D	E	F*	SHAFT			ISO FLANGE			WAFER N	LUG N	O	P	Weight lb. (kg)
							G	H	J	K	L	M					
2 (50.8)	8.781 (223)	8.250 (209.6)	5.531 (140.5)	3.609 (91.7)	0.469 (11.9)	1.800 (45.7)	1.313 (33.3)	0.625 (15.9)	0.439 (11.2)	0.406 (10.3)	4.021 (102.1)	0.500 (12.7)	0.750 (19.1)	5/8 - 11	4.750 (120.7)	1.688 (42.9)	6 (2.7)
3 (76.2)	10.063 (255.6)	9 (228.6)	6.313 (160.3)	5 (127)	0.689 (17.5)	2.594 (65.9)	1.313 (33.3)	0.625 (15.9)	0.439 (11.2)	0.406 (10.3)	4.021 (102.1)	0.875 (22.2)	0.750 (19.1)	5/8 - 11	6 (152.4)	1.813 (46)	9 (4.1)
4 (101.6)	11.313 (287.3)	10.250 (260.4)	6.813 (173)	6 (152.4)	1 (25.4)	3.469 (88.1)	1.313 (33.3)	0.625 (15.9)	0.439 (11.2)	0.406 (10.3)	4.021 (102.1)	0.875 (22.2)	0.750 (19.1)	5/8 - 11	7.500 (190.5)	2.063 (52.4)	14 (6.3)
6 (152.4)	14.094 (358)	12.219 (310.4)	8.063 (204.8)	8.250 (209.6)	1.875 (47.6)	5.500 (139.7)	1.313 (33.3)	1 (25.4)	0.834 (21.2)	0.406 (10.3)	4.021 (102.1)	1.500 (38.1)	0.875 (22.2)	3/4 - 10	9.500 (241.3)	2.219 (56.4)	25 (11.3)
8 (203.2)	17.188 (436.6)	15.375 (390.5)	10.13 (257.3)	10.25 (260.4)	2.689 (68.3)	7.375 (187.3)	1.313 (33.3)	1 (25.4)	0.834 (21.2)	0.406 (10.3)	4.021 (102.1)	1.500 (38.1)	0.875 (22.2)	3/4 - 10	11.750 (298.5)	2.375 (60.3)	34 (15.3)
10 (254)	21.094 (535.8)	19.400 (493.0)	12.313 (312.7)	12.250 (311.2)	3.625 (92.1)	9.563 (242.9)	1.750 (44.5)	1.375 (34.9)	1.000 (25.4)	0.531 (13.5)	4.921 (125)	1.500 (38.1)	1 (25.4)	7/8 - 9	14.250 (362)	2.688 (68.3)	52 (23.4)
12 (304.8)	23.750 (603.8)	21 (533.4)	13.313 (338.1)	14.375 (365.1)	4.438 (112.7)	11.563 (293.7)	21.25 (54)	1.375 (34.9)	1.000 (25.4)	0.531** (13.5)**	4.921 (125)	1.500 (38.1)	1 (25.4)	7/8 - 9	17 (431.8)	3.094 (78.6)	65 (29.3)

NOTE: *Lined Piping which exceeds liner thickness specification of ASTM F1545 may require spacers to avoid disc swing.
**10" & 12" valve size only, the operator mounting holes are offset 15°

Fasteners for Installation of Lug Bodies							
Valve Size in.	2	3	4	6	8	10	12
Number of Fasteners	8	8	16	16	24	24	24
Thread Call-out	5/8 - 11 UNC			3/4 - 10 UNC		7/8 - 9 UNC	
"A" Length of Fastener	1-1/2	1-3/4	1-3/4	2	2-1/4	2-1/2	2-1/2

Fasteners for Installation of Wafer Bodies							
Valve Size in.	2	3	4	6	8	10	12
Number of Fasteners	4	4	8	8	8	12	12
Thread Call-out	5/8 - 11 UNC			3/4 - 10 UNC		7/8 - 9 UNC	
"B" Length of Fastener	5	5-1/2	5-3/4	6-1/2	6-3/4	7-3/4	8-1/4



DURCOR® STRUCTURAL COMPOSITE PTFE LINED PIPING SYSTEM



DURCOR® STRUCTURAL COMPOSITE PFA LINED VALVES



800 SERIES - PTFE/PFA LINED



860 SERIES - RESILIENT SEATED



PURESITE™ - UNBREAKABLE FEP



BLUELINE™ EXPANSION JOINTS

TRULY VISIONARY



INNOVATION



AUTOMATED VALVES

CL2™ CHLORINE HOSE



100% COMPLIANT WITH CHLORINE INSTITUTE

PTFE/FEP/PFA HOSE & FITTINGS



TASK-LINE® - GROUNDING PADDLES



TASK-LINE® - LINE BLOCKERS



TASK-LINE® - GASKETS

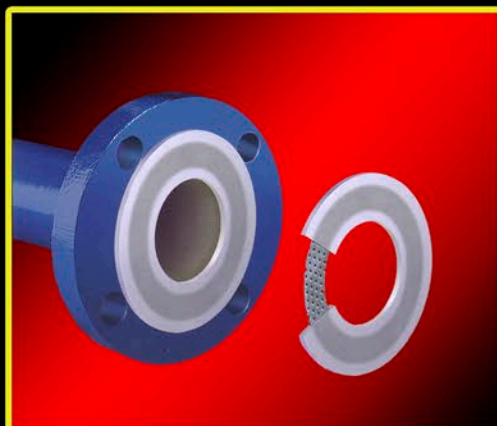

HEATED HOSES



PLATINUM CURED SILICONE



HOW TO ORDER & SPECIFY

EXAMPLE:

6" WAFER STYLE VALVE WITH PTFE SEAT, SILICONE ENERGIZER, PFA LINED DISC, B7 PTFE COATED BOLTS, BARE STEM VALVE

PART NUMBER: **80006WO11T01**

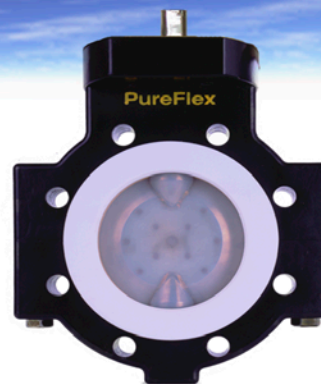

STEP 1 STEP 2 STEP 3 STEP 4 STEP 5 STEP 6 STEP 7
800 - **06** - **WO** - **1** - **1** - **T** - **01**

STEP 1

800 = BUTTERFLY VALVE

STEP 2

DETERMINE VALVE SIZE

02 = 2" (50MM)
 03 = 3" (80MM)
 04 = 4" (100MM)
06 = 6" (150MM)
 08 = 8" (200MM)
 10 = 10" (250MM)
 12 = 12" (300MM)

STEP 3

DETERMINE VALVE BODY STYLE

WO = FLANGED WAFER (STD.)
 LC = LUG COMPOSITE THREADS

STEP 4

DETERMINE SEAT (WETTED) AND ENERGIZER (NON-WETTED) MATERIAL

1 = PTFE / SILICONE (STD.)
 2 = PTFE / VITON
 3 = UHMWPE / SILICONE
 4 = UHMWPE / VITON
 5 = TFM / SILICONE
 6 = TFM / VITON

STEP 5

DETERMINE DISC MATERIAL

1 = PFA LINED DUCTILE IRON (STD.)
 2 = 316 STAINLESS
 3 = HASTELLOY C276
 4 = UHMWPE LINED STAINLESS
 5 = TITANIUM GRADE C-2
 Z = SPECIAL

STEP 6

DETERMINE BODY BOLT MATERIAL

T = GRADE B7 PTFE COATED (STD.)
 P = GRADE B7 ZINC PLATED
 S = GRADE B8 STAINLESS
 A = ALLOY 20
 H = HASTELLOY C276
 Z = SPECIAL

STEP 7

DETERMINE VALVE OPERATOR

01 = BARE STEM (STD.)
 02 = 10 POSITION DI WRENCH
 S2 = 10 POSITION S.S. WRENCH
 03 = WORM GEAR CAST IRON
 S3 = WORM GEAR STAINLESS
 04 = PADLOCKING GEAR CAST IRON
 S4 = PADLOCKING GEAR STAINLESS
 05 = AIR ACTUATED
 06 = ELECTRIC ACTUATED
 ZZ = SPECIAL

1. Scope

- 1.1 The following product specification applies to lined butterfly valves for chemical and/or abrasive service. Valve shall be rated for 150psi continuous service and have temperature rating of (-)60°F to +250°F. Valves must be bubble tight in the closed position.
- 1.2 It is recommended that you check chemical compatibility with your material selection.

2. Valve Body

- 2.1 Valve body shall be manufactured from vinyl ester and Fiberglass composite. The valve body shall be full-face flange wafer or lug style for end of the line service. Valve body shall be capable of direct threading for lug style and threads shall have nominal pullout strength of 250ft lbs.
- 2.2 Valve body composite shall have a nominal tensile strength of 50,000 psi as per ASTM D-256.
- 2.3 Valve body composite shall have a nominal notched izod impact strength of 30ft lb. per inch of 1760 J/M.
- 2.4 Valve shall be equipped with operator mounting flange that is compliant to ISO 5211 and flange fasteners shall not be pressure retaining.

3. Valve Seat Energizer

- 3.1 Valve seat shall be molded and machined PTFE or UHMWPE depending on service conditions with a nominal wall thickness of .125 capable of full vacuum at maximum temperature rating.
- 3.2 Valve sealing face of seat shall be recessed into valve body to eliminate liner cold flow (creep). Wetted elastomers shall not be allowed.
- 3.3 Valve seat non-wetted energizer shall be either Silicone or Viton and shall be one piece permanently attached to valve seat.

4. Valve disc and stem

- 4.1 Disc and stem shall be one-piece blowout resistant type and stem shall be double "D" machined where operator is attached. Two piece stem and disc and exposed fasteners on disc shall not be allowed.

- 4.2 Disc shall be lined or unlined. Lined discs shall be encapsulated with PFA or UHMWPE and have a nominal liner thickness of .125". Unlined discs shall be stainless steel, Hastelloy C276 or Titanium. Disc material shall be determined by service conditions.
- 4.3 Stem shall have machined locking barbs at both ends of disc to provide torturous no leak path with valve seat.
- 4.4 Valve stem shall have top and bottom PTFE composite stem bearings.

5. Valve triple stem seals

- 5.1 Valve shall have matching radii molded seat and disc (ball and socket)
- 5.2 Valve shall have tight compression around stem maintained by resilient energizer against valve seat.
- 5.3 Valve shall have live loaded stainless steel tapered rings on both ends of disc that compress energized valve seat onto locking barbs on stem to provide sealing.

6. Valve fasteners

- 6.1 Valve body fasteners shall be hex head cap screws.
- 6.2 Fasteners shall be PTFE coated B7 A193 standard material. Optional materials can be B7 zinc plated, B8 stainless steel, alloy 20 or Hastelloy.

7. Valve testing

- 7.1 Valve seat to exceed testing criteria of API-598. Valve shall be hydrostatically tested at 165 psi and maintain bubble tight when the disc is in the closed position and valve stems tested to 225 psi. All valves shall be tagged per MSS-SP25 for identification and shall have a unique serial number.

8. Valve manufacturer

- 8.1 Valve shall be manufactured by PureFlex, Inc.: 4855 Broadmoor Ave. Kentwood, MI 49512 Ph: 616-554-1100 Fax: 646-554-3633 www.pureflex.com

PUREFLEX, INC. INFORMATION IS BASED ON TECHNICAL DATA AND TESTING THAT PUREFLEX BELIEVES TO BE RELIABLE AND IS SUBJECT TO CHANGE WITHOUT NOTICE. THE INFORMATION IS INTENDED FOR USE BY PERSONS HAVING TECHNICAL SKILL, AT THEIR OWN DISCRETION AND RISK. SINCE CONDITIONS OF PRODUCT ARE OUTSIDE OF PUREFLEX, INC CONTROL, PUREFLEX, INC MAKES NO WARRANTIES, EXPRESS OR IMPLIED, AND ASSUMES NO LIABILITY IN CONNECTION WITH ANY USE OF THIS INFORMATION. PUREFLEX®, TASK-LINE® AND DURCOR®-62™ ARE TRADEMARKS OF PUREFLEX, INC. HASTELLOY IS A REGISTERED TRADEMARK OF HIGH PERFORMANCE ALLOYS

PureFlex[®]
 an ANDRONACO INDUSTRIES company

4855 BROADMOOR AVE. - KENTWOOD, MI 49512
 PH (616)554-1100 - FAX (616)554-3633
 WWW.PUREFLEX.COM

8000101-0615