

VALMATIC®



**AWWA
Rubber Seated
Ball Valve**



www.valmatic.com

Meets AWWA C507
NSF/ANSI 61 & 372 Certified

Feature Highlights

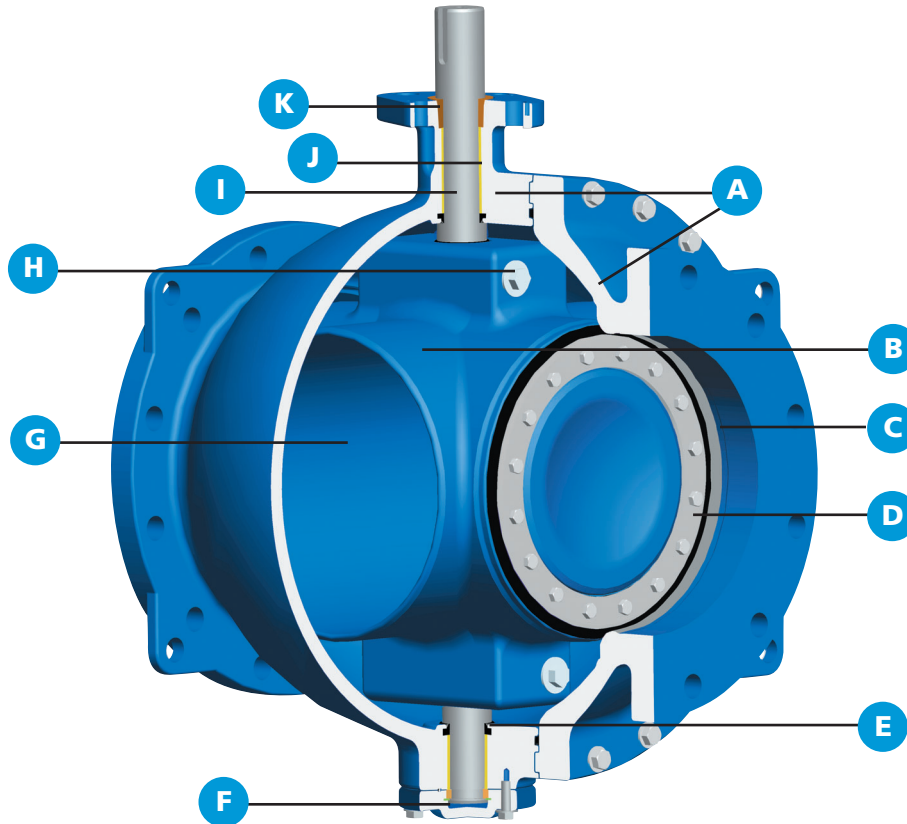

A. Body

The valve body consists of a main body section and end piece. The body design includes integral support legs and fully complies with AWWA Standard C507.

B. Ball

In the open position, the Ball provides a 100% clear flow, unobstructed circular opening. As the ball turns through its 90° travel, it provides a self-flushing (cleaning) action to the valve cavity between the body and ball. When fully closed, drop tight seating is provided.

C. Body Seat

Type 316 Stainless Steel provides extended life and a corrosion free mating surface for the resilient seat retained on the quarter turn ball.

D. Resilient Seating System

Tri-Loc™ Seating System with over 40 years of proven dependability is easily adjusted and field replaceable. All seat-retaining components are Type 316 Stainless Steel.

E. Grit Guard™ Seals

Grit Guard™ seals have been protecting Val-Matic valve bearings in raw sewage application with proven reliability for over 25 years.

F. Thrust Bearing Assembly

The thrust bearing is adjustable and pre-set at the factory.

G. FBE Coating

All valves are provided with fusion bonded epoxy which provides the highest level of corrosion protection and smooth flow surfaces for low headloss.

H. Taper Pins

Stainless steel taper pins provide over 40 years of proven dependability. The taper pin design locks the ball to the shaft and utilizes a Type 316 stainless steel bolt to maintain the lock during severe service.

I. Shafts

Large diameter stainless steel shafts are sized to provide maximum wear resistance with minimum stress during the most severe service conditions.

J. Shaft Sleeve Bearings

The teflon-lined shaft bearings provide low friction and high wear resistance.

K. Shaft Seal

The shaft seal is self-adjusting/wear compensating V-Type packing. The packing is field replaceable without removal of the valve from the line or valve disassembly.

Preferred Features & Benefits

With over 50 years of combined Ball Valve knowledge in the areas of Engineering, Manufacturing, Application and Design, the Val-Matic Ener•G® AWWA Rubber Seated Ball Valve has proven and preferred design features and advanced technology that only Val-Matic experience can provide. The Val-Matic Ener•G® Ball Valve is designed for tight seating, long life and energy savings.

Tight Seating

The resilient seat is based on technology with proven field use for over 40 years. Both single and double-seated valves are available for sealing in one or two directions. When fully open, the resilient seat is completely out of the flow stream.

Structural Integrity

The valve body is built with a main section and an end piece that are connected with precision registers and o-ring seals to withstand the rigors of pipeline service.

Tri-Loc™ Seat Retention System

Proven dependability since 1971, the Tri-Loc™ seat retention system provides positive mechanical retention of the valve seat while allowing easy adjustment or replacement. The seat is secured by three methods: clamp force, through-bolting and opposing registers in the ball and the seat retaining ring. Clamp force is provided by tightening nylok cap screws. These same screws provide through-bolting seat retention by passing through the precision molded holes in the resilient seat. Finally, molded shoulders in the seat are captured by registers and serrations in the ball and the retaining ring preventing outward movement of the seat.

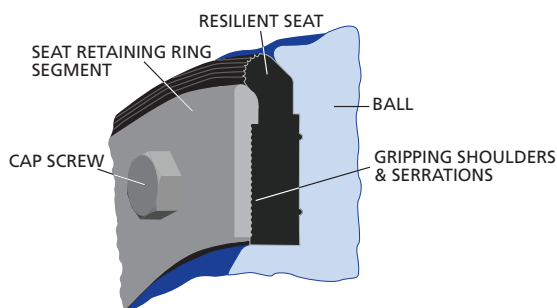

Energy Savings

In these times of conservation and “Green” design, there is no better valve than the Val-Matic Ener•G® AWWA Ball Valve. When fully open, the valve provides 100% clear flow area equal to the valve size. Hence, the valve headloss is equal to an equivalent length of pipe and will represent a significant savings in pumping costs.

Proof of Design Tested

The Val-Matic Ener•G® Ball Valve is certified to rigorous pressure and cycle proof of design tests per

AWWA C507. The valves were full-scale flow tested and operated at velocities exceeding 40-ft/sec at an independent laboratory.

Fusion Bonded Epoxy Coating

All Val-Matic Ener•G® Ball Valves are coated inside and out with NSF 61 fusion bonded epoxy per AWWA C550. The valve and its components are specifically designed for continuous uninterrupted fusion bonded epoxy coating. The interior and exterior are coated with fusion bonded epoxy for long life.

Proven Actuation

Val-Matic traveling nut actuators have been proven in rigorous field installations for over 40 years. Advances in design include ductile iron housings and levers, 450 ft-lb stops, **exclusive** externally adjustable closed stops and fully sealed housings. Traveling nut actuators can be fitted with stainless steel or non-metallic cylinders for hydraulic actuation.

Serviceability

If repairs become necessary, the valve is designed for easy field maintenance and repair. The shaft seal incorporates self-adjusting V-type packing, which is easily replaced in the field without removal from the line. Adjustment of the resilient seat is easily performed with a hand wrench. No two-part epoxy, hypodermic needles or pressure pots are required. The seat can be replaced with the valve in line.

Designed for Wastewater Service

The Ball Valve’s clear flow path makes it ideal for wastewater service. However, Val-Matic takes additional steps to ensure its performance in wastewater by providing Grit Guard™ seals and a self-flushing action. The grit seals provide a seal between the shaft and body. These seals protect the body from corrosion and the bearings from premature wear. The ball is designed so there is a significant flushing action between the body and outside of the ball to prevent clogging in wastewater service.

Advanced Technology

Incorporating the latest in valve technology assures a high-quality valve that will provide long service. The design process utilized Solid Modeling and Finite Element Analysis (FEA) of the key structural components. Flow and torque data was derived from flow tests, mathematical models and Computational Fluid Dynamics (CFD). Manufacturing technology uses automated process control in the foundry and ISO 9001 controlled manufacturing processes. Every valve is tested in accordance with AWWA C507 on automated hydraulic test rigs with calibrated gauges.

Valve Construction

PRESSURE RATINGS

MAXIMUM PRESSURE RATINGS			
SERIES	CONFIGURATION	AWWA Class	CWP (psig)
4100	ANSI 125# Gray Iron - Single Seat	150D	150
4200	ANSI 125# Gray Iron - Double Seat	150D	150
4300	ANSI 250# Ductile Iron - Single Seat	300D	300
4400	ANSI 250# Ductile Iron - Double Seat	300D	300
4500	ANSI 150# Ductile Iron - Single Seat	250D	250
4600	ANSI 150# Ductile Iron - Double Seat	250D	250

MATERIALS OF CONSTRUCTION

COMPONENT	STANDARD	OPTIONAL
Body Class 150D	ASTM A126 Class B	
Body Class 250D/300D	ASTM A536 Gr 65-45-12	
Ball Class 150D	ASTM A126 Class B	
Ball Class 250D/300D	ASTM A536 Gr 65-45-12	
Shaft Class 150D	ASTM A276 Type 304	Type 316
Shaft Class 250D/300D	ASTM A563 Type 630	
Resilient Seat	EPDM	Buna-N
Body Seat and Hardware	Type 316 Stainless Steel	
Shaft Bearings	Teflon-Lined, Fiberglass Backed	Bronze
Grit Seal	Molythane	
V-Packing	Buna-N	

Headloss Chart

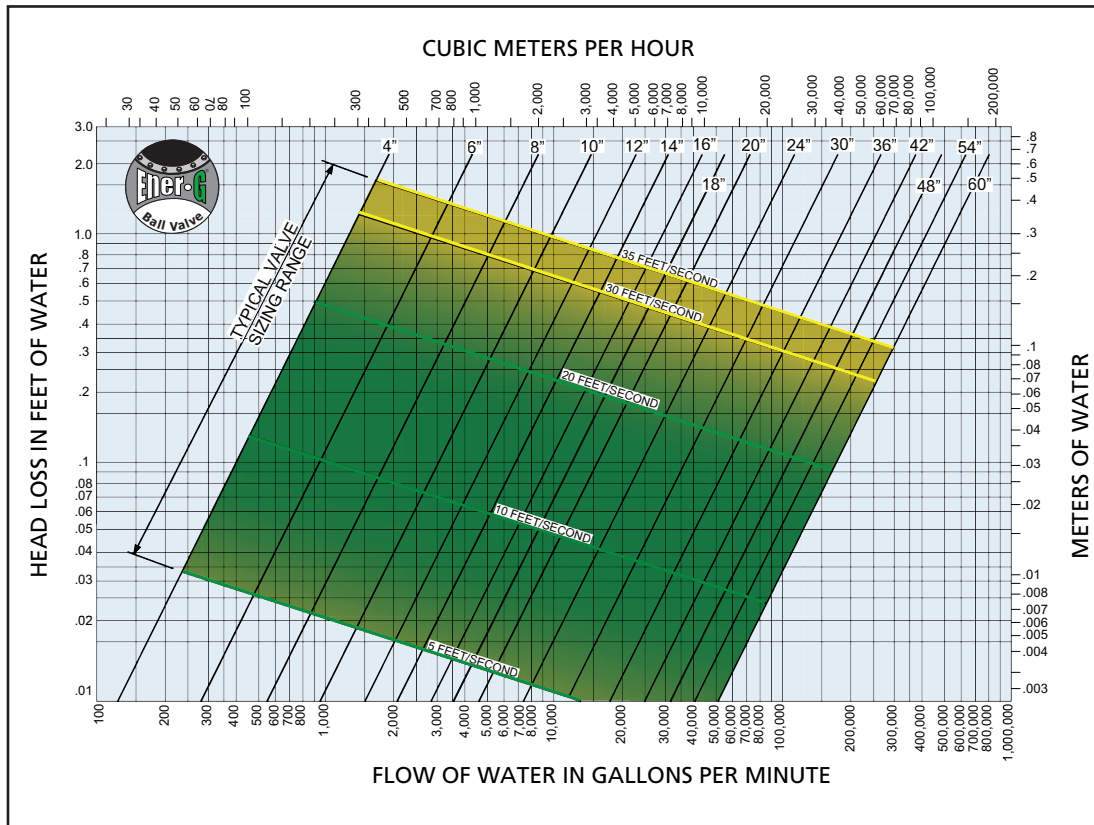

Flow Coefficients	
Size	Cv
4"	1,910
6"	4,310
8"	8,520
10"	14,700
12"	22,800
14"	30,500
16"	42,700
18"	56,100
20"	70,500
24"	106,000
30"	172,000
36"	257,000
42"	369,000
48"	480,000
54"	620,000
60"	775,000

Energy Cost Savings

An important characteristic of valves in water pumping systems that is often overlooked is the valve's ability to minimize energy consumption. Common flow coefficients for various valves used in pumping systems are shown below. Since Cv represents the flow through a valve with a 1 psi pressure drop, we can see that a Ball Valve provides the lowest headloss characteristics.

12 in. Valve Flow Data			
Type of Valve	Cv	ΔH	40-Year Energy Cost*
Swing Check & Weight	3,395	3.58	\$49,900
Globe-Style Control Valve	1,800	12.75	\$177,800
Butterfly Valve	6,550	0.96	\$13,400
Eccentric Plug Valve	4,750	1.81	\$25,300
Ener•G® AWWA Ball Valve	22,800	0.07	\$936

* Assumes 50% usage over 40 years, \$.08/kw-hr, 12 ft/sec velocity, 0.8 efficiency

The headloss from valves can be converted into the energy cost related to the pumping electrical power needed to overcome the additional headloss from the valve with the equation:

$$A = (1.65 Q \Delta H S_g C U) / E$$

Where:

- A = annual energy cost, dollars per year
- Q = flow rate, gpm
- ΔH = head loss, ft. of water
- Sg = specific gravity, dimensionless
- C = cost of electricity, \$/kW·h
- U = usage, percent
- E = efficiency of pump/motor set

The table shows that the Val-Matic Ener•G® AWWA Ball Valve with its low energy cost pays for itself over its life. It consumes less than 1% the energy of a Globe-Style Control Valve. Larger systems and systems operating at higher velocities will provide even greater savings.

If your goal is to design a "Green" pumping system, the Val-Matic Ener•G® Ball Valve is the valve of choice.

Flow Characteristics

Inherent Flow Characteristics

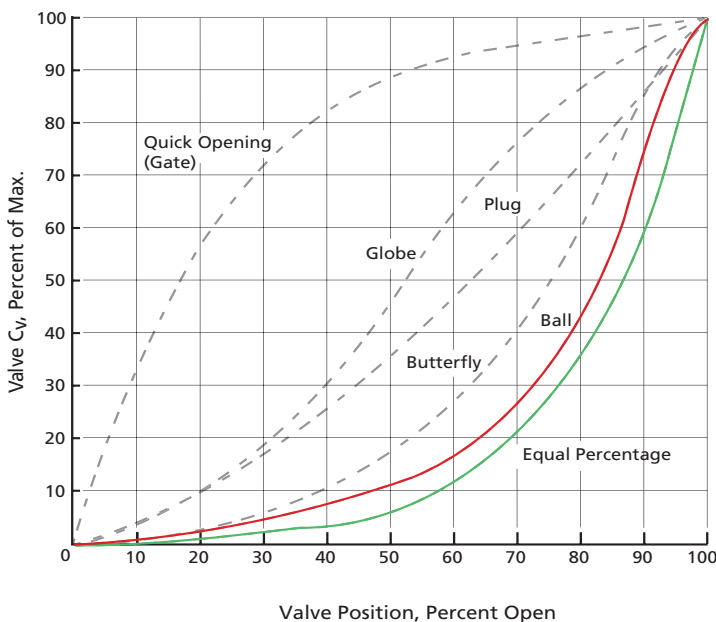

In addition to being the best selection for energy savings, the Val-Matic Ener•G® Ball Valve is the best selection for surge control. Its inherent flow characteristics are highly suited to control flow and pressure.

Some valves like Globe and Plug will linearly reduce the flow rate in proportion to the movement of the closure member. Quick Opening valves, such as Gate Valves, only affect the flow during the last 30% of their closure. Equal percentage valves, like the Ball Valve, uniformly change the flow rate during the full travel.

The graph below provides the Inherent Flow Characteristics of various types of valves. The data is expressed in terms of flow coefficient (Cv) at various percents of the valve's position. The most desirable flow characteristic for surge control is equal percentage as provided by the Val-Matic Ener•G® Ball Valve.

Pump Control Ball Valve

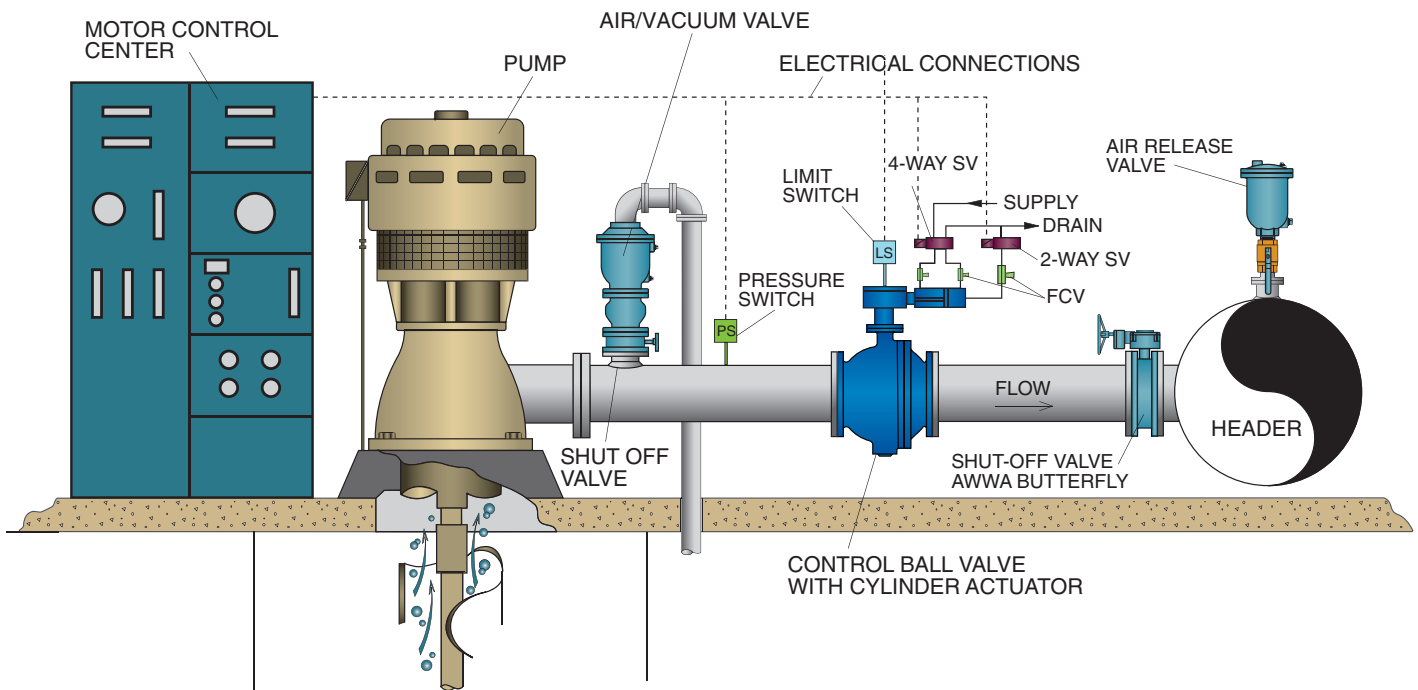

Typical Pump Control System
(Single or Multiple Pump)

Pump Control Ball Valves

For pumping systems where surge control is critical and energy savings are important, a pump control ball valve is preferred. The valve is wired to the pump controls and provides adjustable opening and closing times in excess of the system critical surge period. Unlike check valves, the pump control ball valve's speed of operation is not affected by line flow or pressure conditions. Stable operating times are essential in controlling surges in pumping systems. A Val-Matic Ener•G® Ball Valve is the ideal pump control valve for pumping systems. Its equal percentage flow characteristics, rugged AWWA construction and negligible headloss make it the preferred choice.

Sequence of Operation

When the pump is started and pressure builds, a pressure switch (PS) located on the pump discharge pipe signals the Ball Valve to open. During shutdown, the valve is signaled to close while the pump continues to run. When the Ball Valve nears the closed position, a limit switch (LS) located on the valve will stop the pump. After a power outage or pump trip, the flow will rapidly reverse. The Ball Valve must close rapidly to prevent backspinning the pump and rapid depletion of a hydro-pneumatic surge tank when utilized.

Cylinder Actuator Control

The Ener•G® Ball Valve is equipped with a hydraulic cylinder actuator. The cylinder can be powered with pressurized water from the line or from an independent oil hydraulic power system. Mounted on the valve or in a floor-mounted panel are the hydraulic controls electrically wired to the pump controls. Solenoid valves (SV) direct the operating medium to the cylinder ports to cycle the valve. The speed of opening and closing is controlled by independently adjustable flow control valves (FCV). The valve hydraulic controls are equipped with a bypass line to send the controlled cylinder flow around the normal flow control valve and through an alternate fast-closing flow control valve.

Motor Actuator Control

Alternatively, when a clean water supply is not available to power a cylinder actuator, such as a lift station application, the Ball Valve can be supplied with a motor actuator. The operating times are adjustable in the field with special actuator motor controls. To protect the pump and system on power failure, the valve can either be supplied with a battery backup system or a Surgebuster® Check Valve. The Surgebuster® provides low headloss and non-slam characteristics.

Control Systems

Hydraulic Panel

The Val-Matic hydraulic control panel uses the highest quality components available and is designed to reliably operate the pump control ball valve with water or oil supply. Unlike a motor-operated control valve, the control panel allows field adjustment of the valve operating times so that the valve can be timed to match the surge characteristics of the piping system. The controls are panel mounted and pre-wired to a terminal strip in a NEMA 4X junction box for easy installation. An optional NEMA 4X enclosure is available to secure and protect the equipment in the harshest of environments.

There are four pressure connections to the cabinet: Supply, Drain, Open, and Close. The supply connection is equipped with an isolation valve and pressure gauge for ease of troubleshooting the control system. The supply and drain headers are controlled by brass two-way normally-open solenoid valves assembled with rigid brass pipe and heavy duty, non-corrosive, quick connect style hose and fittings. They provide rapid valve closure upon electrical power failure to minimize backspinning of the pump. The emergency closure rate is adjustable in the 10-30 second range by the balancing valve in the bottom header. The normal open and closing of the pump control valve is controlled by the brass four-way solenoid valve and independently adjustable multi turn flow control valves. The flow control valves allow independent control of the operating times in the 30-600 second range.

The solenoid valves are wired to a NEMA 4X junction box using liquid-tight conduit. The solenoid valve wires are terminated inside of the junction box with terminals. Installation of the system is easy and fast since only one conduit connection is needed to connect the panel to the pump controls.

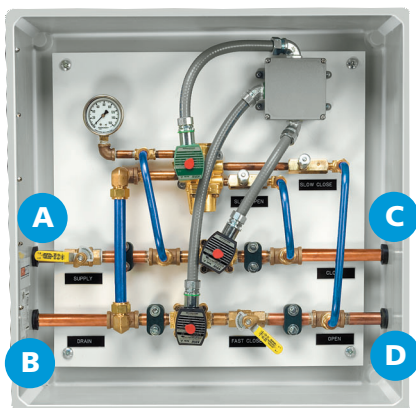

Hydraulic Panel

- A. Supply Pressure
- B. Drain
- C. Pressure to Close
- D. Pressure to Open

Electric Panel

The Val-Matic electrical control panel uses the highest quality components available and is designed to work with the hydraulic panel in controlling and monitoring the operation of the pump control ball valve. The relays and timers are panel mounted and pre-wired to a terminal strip in a hinged NEMA 4X enclosure for easy installation and to protect the equipment in the harshest of environments.

The control panel includes internal plug-in type Run and Stop Relays to control the operation of the pump. An adjustable Timing Relay monitors the operation of the system and automatically shuts down the pump if the pump does not build pressure or the valve fails to open. Transformer-type Pilot Lights are used to provide safe indication. The RUN, OPEN, and CLOSE pilot lights indicate valve and pump operation. The STOP light indicates that an alarm condition exists and the pump is locked out. Once the alarm condition is resolved, the RESET button is pressed to activate the system. An EMERGENCY STOP button is provided to stop the pump at the valve location. When the button is pressed, the valve closes at the normal rate, and automatically shuts off the pump when the closed limit switch is tripped.



Electric Panel

Exclusive Val-Matic Control System Features for Hydraulic and Electric Panels

- Waterproof and corrosion-resistant enclosures
- Rigid brass pipe with heavy duty hose and fittings
- Supply line with isolation valve and pressure gauge
- Reliable ASCO solenoid valves and vernier flow control valves
- Heavy-Duty switches and transformer pilot lights

Oil Accumulator Systems

Oil Accumulator Systems include an electrical panel, ASME pressure tank, dual oil pumps and dual air compressors are skid-mounted and supply a safe and steady 80-125 psig oil supply pressure to the pump control valve, even after power failure.



Oil Accumulator System

Manual Actuated Valves

Installation Dimensions

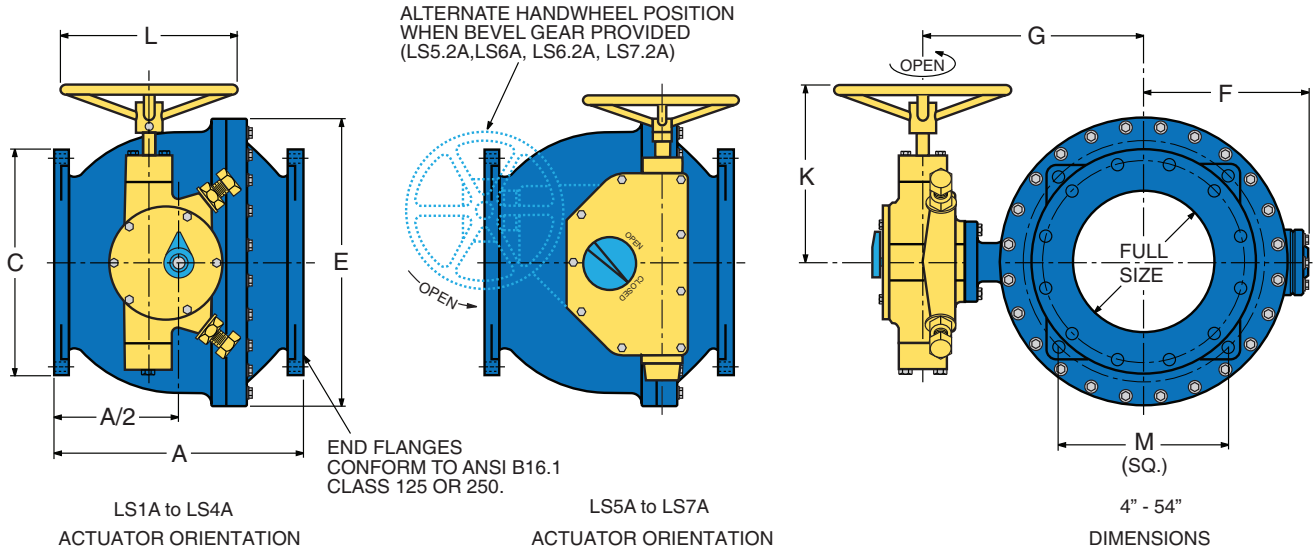

Val-Matic's traveling nut manual actuators are designed to specifically match the torque characteristics of the Val-Matic Ener•G® Ball Valve and are built in accordance with AWWA Standard C507 for Ball Valves. The traveling nut actuator provides characterized closure which allows the valve to slowly close during the last half of travel to reduce pipeline surges. Val-Matic actuators have the exclusive features of externally adjustable stops rated to 450 ft-lbs of input torque.

Dimensions in Inches

Valve Size	AWWA Class	Actuator Size*	No. of Turns	A	C	E	F	G	K	L	M
4	150	LS-1A	15	12.38	9.00	11.75	7.25	10.25	9.38	8	7.11
	300	LS-1A	15	13.00	10.00	11.75	7.25	10.50	9.38	8	7.87
6	150	LS-2.2A	20	15.75	11.00	14.75	8.50	11.38	11.25	12	8.57
	300	LS-2A	20	16.00	12.50	15.00	9.50	12.38	11.25	12	9.63
8	150	LS-2A	20	18.00	13.50	17.88	10.38	13.63	11.25	12	10.34
	300	LS-3.2A	35	18.00	15.00	18.13	11.75	16.13	13.88	12	11.49
10	150	LS-3A	35	19.50	16.00	21.13	12.38	16.00	13.88	12	12.20
	300	LS-3A	35	21.13	17.50	21.63	13.88	17.50	13.88	12	13.34
12	150	LS-3A	35	21.00	19.00	24.25	14.38	18.13	14.88	16	14.32
	300	LS-3A	35	24.00	20.50	24.50	16.50	20.25	14.88	16	15.55
14	150	LS-3A	35	26.25	21.00	27.50	16.38	20.00	14.88	16	15.82
	300	LS-4A	50	27.75	23.00	27.75	18.75	22.63	19.88	24	17.32
16	150	LS-3A	35	27.00	23.50	30.63	18.63	22.25	14.88	16	17.59
	300	LS-4A	50	28.13	25.50	31.63	21.75	25.63	21.38	30	19.18
18	150	LS-4A	50	30.00	25.00	33.88	20.38	24.38	21.38	30	18.74
	300	LS-4A	50	31.00	28.00	34.50	23.63	27.63	21.38	30	20.94
20	150	LS-4A	50	32.00	27.50	36.75	21.88	25.75	21.38	30	20.50
	300	LS-5.3A	100	34.00	30.50	37.38	25.81	30.50	23.97	16	22.71
24	150	LS-5A	100	37.00	32.00	43.13	26.25	31.50	28.25	24	23.77
	300	LS-5A	100	42.75	36.00	43.63	30.88	36.13	28.25	24	26.78
30	150	LS-5.2A	255	46.00	38.75	52.44	31.03	35.50	20.13	16	28.55
	300	LS-5.2A	255	50.25	43.00	53.44	37.25	42.50	20.13	24	39.99
36	150	LS-5.2A	255	54.00	46.00	62.00	38.13	43.38	19.50	24	33.85
	300	LS-6A	425	54.00	50.00	63.00	44.88	51.50	24.88	24	37.12
42	150	LS-6.2A	425	59.50	53.00	71.06	43.75	50.25	24.88	24	38.80
	300	LS-6.2A	425	61.00	57.00	72.56	51.50	58.00	24.88	30	42.07
48	150	LS-6.2A	425	72.00	59.50	79.69	49.50	55.63	24.88	30	43.39
	300	LS-7.2A	720	76.50	65.00	81.19	58.38	67.00	32.25	30	47.72
54	150	LS-6.2A	425	82.00	66.25	89.50	55.00	64.50	24.88	30	49.67
		LS-7.2A	720					67.00			

*Actuator sizes vary with flow and pressure conditions.

Cylinder Actuated Valves

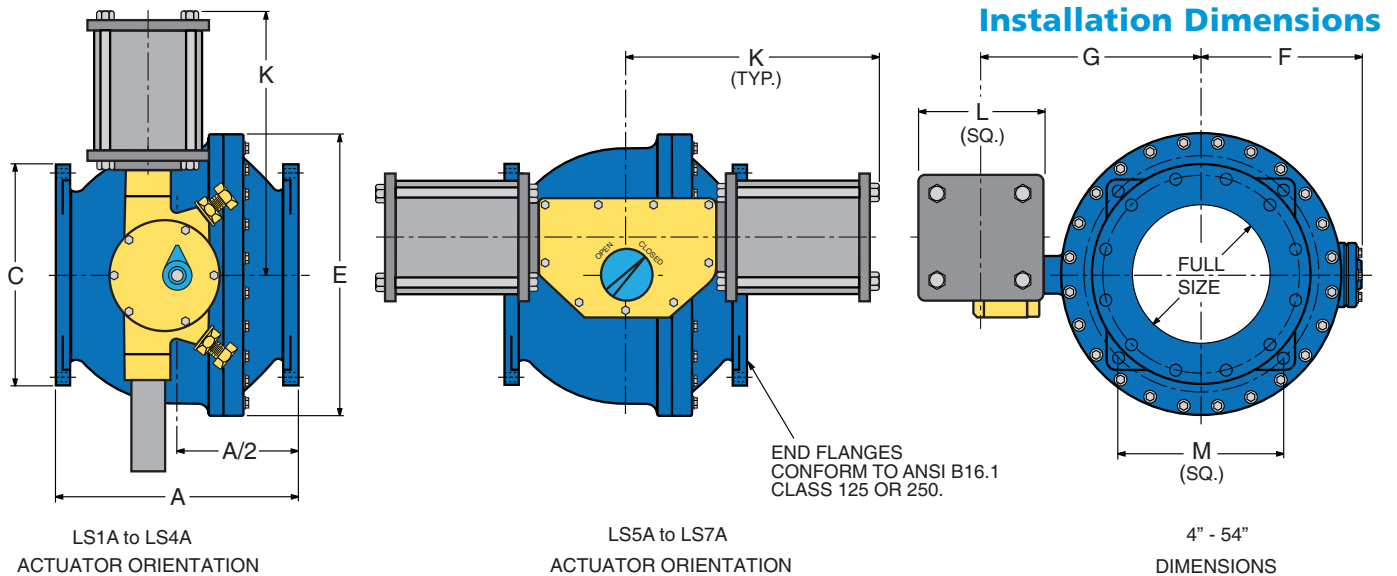

Val-Matic's traveling nut cylinder actuators provide reliable characterized closure and are designed and built in accordance with AWWA Standards C507 for Ball Valves and C541 for Hydraulic and Pneumatic Cylinder and Vane-Type Actuators for Valves and Slide Gates and feature externally adjustable closed stops for easy adjustment. The cylinder heads and barrels are constructed of stainless steel or non-metallic materials and include large NPT ports. The stainless steel piston is fitted with a wear strip for long and reliable seal life. The seals are suitable for air, oil or water supply media to 150 psig and are replaceable without removing the cylinder from the actuator unit.

Dimensions in Inches											
Valve Size	AWWA Class	Actuator Size*	Cylinder Bore	A	C	E	F	G	K	L	M
4	150	LS-1A	6	12.38	9.00	11.75	7.25	10.25	14.00	6.75	7.11
	300	LS-1A	6	13.00	10.00	11.75	7.25	10.50	14.00	6.75	7.87
6	150	LS-2A	6	15.75	11.00	14.75	8.50	11.00	14.00	6.75	8.57
	300	LS-2A	8	16.00	12.50	15.00	9.50	12.38	16.88	8.75	9.63
8	150	LS-2A	8	18.00	13.50	17.88	10.38	13.63	16.88	8.75	10.34
	300	LS-3A	10	18.00	15.00	18.13	11.75	16.13	24.38	10.88	11.49
10	150	LS-3A	10	19.50	16.00	21.13	12.38	14.88	18.38	10.88	12.20
	300	LS-3A	10	21.13	17.50	21.63	13.88	17.50	24.38	10.88	13.34
12	150	LS-3A	10	21.00	19.00	24.25	13.96	18.56	23.43	10.88	14.32
	300	LS-3A	12	24.00	20.50	24.50	16.50	20.25	24.38	12.88	15.55
14	150	LS-3A	12	26.25	21.00	27.50	16.38	20.00	24.38	12.88	15.82
	300	LS-3A	12	27.75	23.00	27.75	18.75	22.63	30.13	12.88	17.32
16	150	LS-3A	12	27.00	23.50	30.63	18.63	22.25	24.38	12.88	17.59
	300	LS-4A	14	28.13	25.50	31.63	21.75	25.63	31.63	15.00	19.18
18	150	LS-4A	12	30.00	25.00	33.88	20.38	24.38	30.13	12.88	18.74
	300	LS-4A	14	31.00	28.00	34.50	23.63	27.63	31.63	15.00	20.94
20	150	LS-4A	14	32.00	27.50	36.75	21.88	25.75	31.63	15.00	20.50
	300	LS-5.3A	14	34.00	30.50	37.38	25.81	30.50	43.44	15.00	22.71
24	150	LS-5A	14	37.00	32.00	43.13	26.25	31.50	42.19	15.00	23.77
	300	LS-5A	18	42.75	36.00	43.63	30.88	36.13	50.00	19.13	26.78
30	150	LS-5.2A	18	46.00	38.75	52.44	31.88	37.13	50.00	19.13	28.55
	300	LS-5.2A	18	50.25	43.00	53.44	37.25	42.50	50.00	19.13	31.99
36	150	LS-5.2A	18	54.00	46.00	62.00	38.13	43.38	50.00	19.13	33.85
	300	LS-6A	18	54.00	50.00	63.00	44.88	51.50	58.88	19.13	37.12
42	150	LS-6.2A	18	59.50	53.00	71.06	43.75	48.88	50.00	19.13	38.80
	300	LS-6.2A	24	61.00	57.00	72.56	51.50	58.00	61.38	25.13	42.07
48	150	LS-6.2A	24	72.00	59.50	79.69	49.50	55.63	61.38	25.13	43.39
	300	LS-7.2A	24	76.50	65.00	81.19	58.38	67.00	75.00	25.13	47.72
54	150	LS-7A	24	82.00	66.25	89.50	55.00	67.00	75.00	25.13	49.67

*Actuator sizes vary with flow and pressure conditions.

Motor Actuated Valves

Installation Dimensions

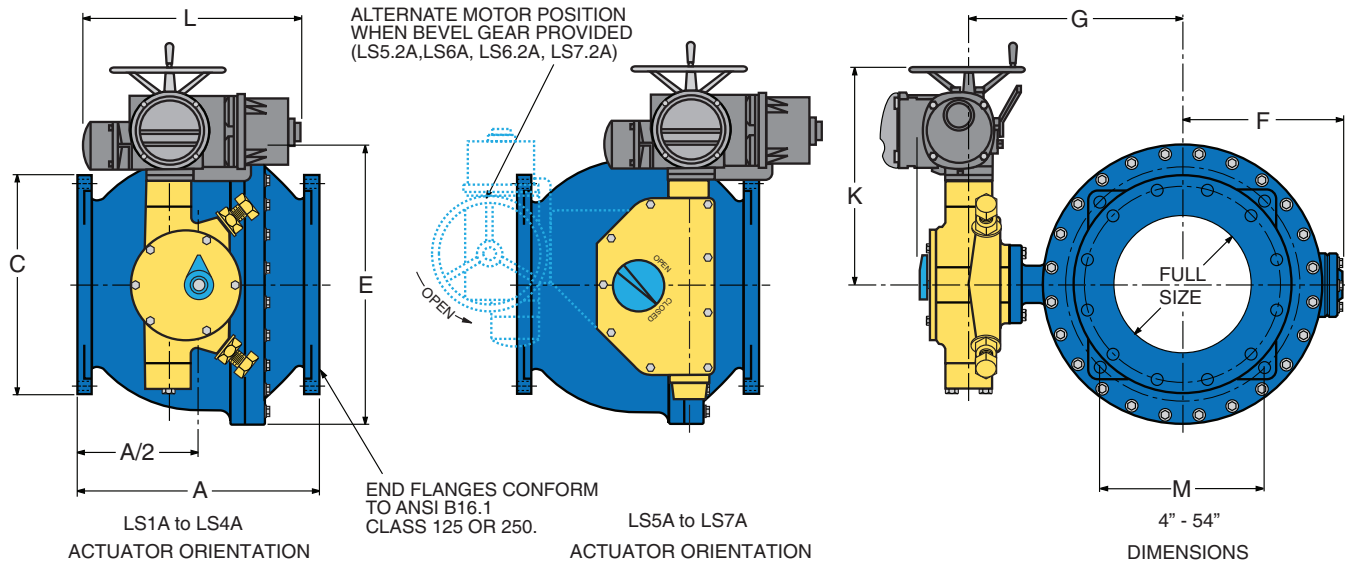

Val-Matic's traveling nut motor actuators are specifically designed to match the torque characteristics of the Val-Matic Ener•G® Ball Valve. The actuators are built in accordance with AWWA Standards C507 for Ball Valves and C542 for Electric Motor Actuators for Valves and Slide Gates and are equipped with externally adjustable stops for easy field adjustment. Motors are available to suit multiple speeds and voltages and are equipped with thermal overloads, torque switches and limit switches to protect the actuator and ball valve. A handwheel gear set with declutch is included to allow users to manually position the valve without electrical power.

Dimensions in Inches

Valve Size	AWWA Class	Actuator Size*	Motor Class	A	C	E	F	G	K	L	M
4	150	LS-1A	M01	12.38	9.00	11.75	7.25	9.56	15.77	23.00	7.11
	300	LS-1A	M01	13.00	10.00	11.75	7.25	10.81	15.77	23.00	7.87
6	150	LS-2A	M01	15.75	11.00	14.63	8.50	11.56	16.59	23.00	8.57
	300	LS-2A	M01	16.00	12.50	14.88	9.50	13.18	16.59	23.00	9.63
8	150	LS-2A	M01	18.00	13.50	17.75	10.38	13.25	16.59	23.00	10.34
	300	LS-3A	M02	18.00	15.00	18.00	11.75	15.68	21.21	26.10	11.49
10	150	LS-2A	M01	19.50	16.00	21.13	12.38	16.56	16.59	23.00	12.20
	300	LS-3A	M02	21.13	17.50	21.63	13.88	16.81	21.21	26.10	13.34
12	150	LS-2A	M01	21.00	19.00	24.13	14.38	17.94	16.59	23.00	14.32
	300	LS-3A	M02	24.00	20.50	24.63	16.50	20.63	21.21	26.10	15.55
14	150	LS-3A	M02	26.25	21.00	27.50	16.38	21.31	21.21	26.10	15.82
	300	LS-4A	M02	27.75	23.00	27.75	18.75	22.25	22.96	26.10	17.32
16	150	LS-3A	M02	27.00	23.50	30.60	18.63	23.25	21.21	26.10	17.59
	300	LS-4A	M02	28.13	25.50	31.44	21.75	26.38	22.96	26.10	19.18
18	150	LS-4A	M02	30.00	25.00	33.88	20.38	24.00	22.96	26.10	18.74
	300	LS-4A	M02	31.00	28.00	34.50	23.63	26.44	22.96	26.10	20.94
20	150	LS-4A	M02	32.00	27.50	36.75	21.88	27.50	22.96	26.10	20.50
	300	LS-5A	M03	34.00	30.50	37.38	25.81	29.81	31.03	26.10	22.71
24	150	LS-5A	M02	37.00	32.00	43.13	26.25	31.13	31.03	26.10	23.77
	300	LS-5A	M02	42.75	36.00	43.63	30.88	34.50	31.03	26.10	26.78
30	150	LS-5.2A	M02	46.00	38.75	52.44	31.03	36.19	25.55	26.10	28.55
	300	LS-5.2A	M02	50.25	43.00	53.44	37.25	41.38	25.55	26.10	31.99
36	150	LS-5.2A	M02	54.00	46.00	62.00	38.13	42.94	25.5	26.10	33.85
	300	LS-6A	M03	54.00	50.00	63.00	44.88	49.81	31.50	26.10	37.12
42	150	LS-6.2A	M03	59.50	53.00	71.06	43.75	49.31	31.50	26.10	38.80
	300	LS-6.2A	M03	61.00	57.00	72.56	51.50	57.13	31.50	26.10	42.07
48	150	LS-6.2A	M03	72.00	59.50	79.69	47.62	55.56	31.50	26.10	43.39
	300	LS-7.2A	M03	76.50	65.00	81.19	56.49	64.44	39.50	26.10	47.72
54	150	LS-7.2A	M03	82.00	66.25	89.50	55.00	65.00	39.50	26.10	49.67

*Actuator sizes vary with flow and pressure conditions.

SCOPE

- 1.1 This specification covers the design, manufacture, and testing of 4"- 54" AWWA Class 150 and 300 Rubber Seated Ball Valves.

STANDARDS AND APPROVALS

- 2.1 The valves shall be designed, manufactured and tested in accordance with American Water Works Association Standard AWWA C507.
- 2.2 The valves shall be certified Lead-Free in accordance with NSF/ANSI 372.
- 2.3 Manufacturer shall have a quality management system that is certified to ISO 9001 by an accredited, certifying body.

DESIGN

- 3.1 The valve shall be constructed with a two-piece body rated for 150 or 300 psi with end flanges in full conformance with ANSI B16.1 Class 125 or Class 250. The main body section and end piece shall contain integrally cast support feet and lifting lugs.
- 3.2 The valve port shall be a 100% clear bore equal to the nominal valve size with no seat hardware in the flow stream when fully open. The ball shall be self-flushing when in intermediate positions for wastewater service.
- 3.3 Double (or single) resilient seats shall provide drop-tight service and shall be located on the ball and mechanically retained with a stainless steel retaining ring and stainless steel nylok cap screws, which shall pass through both the resilient seat and the retaining ring. The retaining ring shall be continuous or investment cast with overlapping sections, serrated grooves and shoulders. The resilient seat shall be field adjustable and replaceable without removing the valve from the pipeline and mate to a continuous 316 stainless steel body seat ring.
- 3.4 Valve shafts shall be inserted into blind hubs in the ball and locked to the ball with taper pins retained with stainless steel jam bolts. The shaft shall be sealed with resilient grit seals in the body bores.
- 3.5 Teflon-lined, fiberglass-backed sleeve bearings shall be located in the body hubs.
- 3.6 An adjustable thrust bearing shall be provided to center the ball in the body.
- 3.7 Shaft seals shall be of the V-type and shall be replaceable without removal of the valve from the line or the shaft from the valve.

ACTUATION

- 4.1 Manual actuators shall be of the traveling nut design with characterized closure per AWWA C507 and equipped with externally adjustable closed position stops capable of withstanding 450 ft-lbs. Actuators shall be lubricated with EP-2 grease and fully enclosed in an iron housing sealed against the entry of water.

- 4.2 Cylinder actuators shall be traveling nut with characterized closure and sized to position the valve with an air, water or oil supply pressure of 80-150 psi and built in accordance with AWWA C541. The rotating mechanism will consist of a lever and traveling nut directly connected to the cylinder rod. The cylinder rod, heads and barrel shall be constructed of stainless steel or non-metallic material for water service. Rod and piston seals shall be of the self-adjustable, wear-compensating type. The piston shall be one-piece with a wear strip.
- 4.3 Motor actuators shall be furnished in accordance with AWWA C542 for Power Actuators and factory tested on the production ball valve. The motor unit shall be mounted to a self-locking traveling nut actuator with characterized closure and externally adjustable closed stop. The motor actuator assembly shall be designed for open/close service with a minimum operating time of 60 sec. The motor unit shall be furnished with a position indicator, independently adjustable, 15-amp limit switches, and adjustable torque sensors to protect the valve indicator. A handwheel with a declutch lever shall be provided so that the handwheel does not rotate during electrical operation. Motors shall be sized with a 1.5 safety factor and a power supply of 230/460V, three phase, 60 Hz AC. Electrical operation shall include Local-Off-Remote selector switch, Local Open/Close push buttons and position indication lamps.

MANUFACTURE

- 5.1 Valve interiors and exteriors shall be coated with an NSF/ANSI 61 certified fusion bonded epoxy in accordance with AWWA C550.
- 5.2 Rubber Seated Ball Valves shall be Val-Matic® Series #4000 as manufactured by Val-Matic® Valve & Mfg. Corporation, Elmhurst, IL. USA.



Val-Matic's quality of design and meticulous workmanship has set the standards by which all others are measured. Quality design features such as the AWWA **Ener-G® Ball Valve** with its energy efficient design, fusion bonded epoxy and adjustable resilient seating....**Cam-Centric® Plug Valves** have more requested features than any other eccentric plug valve....**American-BFV® Butterfly Valves** include a field replaceable seat without the need for special tools....**Tilted Disc® Check Valves** with high strength and wear resistant aluminum bronze trim as standard....**Silent Check Valves** featuring combined resilient/metal-to-metal seating and are **NSF/ANSI 61 & 372 Certified**....**Sure Seal Foot Valves** provided with a heavy duty stainless steel screened inlet....**Swing-Flex® and Surgebuster® Check Valves** designed with an unrestricted full flow area....**Swing Check Valves** with field adjustable closure

versatility....**Dual Disc® Check Valves** utilizing stabilized components to provide extended life....**Air Release, Air/Vacuum and Combination Air Valves** provided standard with Type 316 stainless steel trim....**VaultSafe®** family of products includes the **FloodSafe® Inflow Preventer, FrostSafe®** two-way damper and the **VentSafe®** vent pipe security cage. The **QuadroSphere® Trunnion Ball Valve** features a unique ball design with recessed surfaces creating additional flow paths to provide a self-cleaning action and reduced wear and torque.

Val-Matic is totally committed to providing the highest quality valves and outstanding service to our customers. Complete customer satisfaction is our goal. **Make the change to quality, specify Val-Matic!**



Val-Matic Valve and Manufacturing Corp.
 905 Riverside Drive, Elmhurst, IL 60126
 Phone: 630-941-7600 • Fax: 630-941-8042
 www.valmatic.com • valves@valmatic.com