

VALMATIC®



Cam-Centric® Standard Port Plug Valves



www.valmatic.com

Meets AWWA C517
NSF/ANSI 372 Certified

Feature Highlights

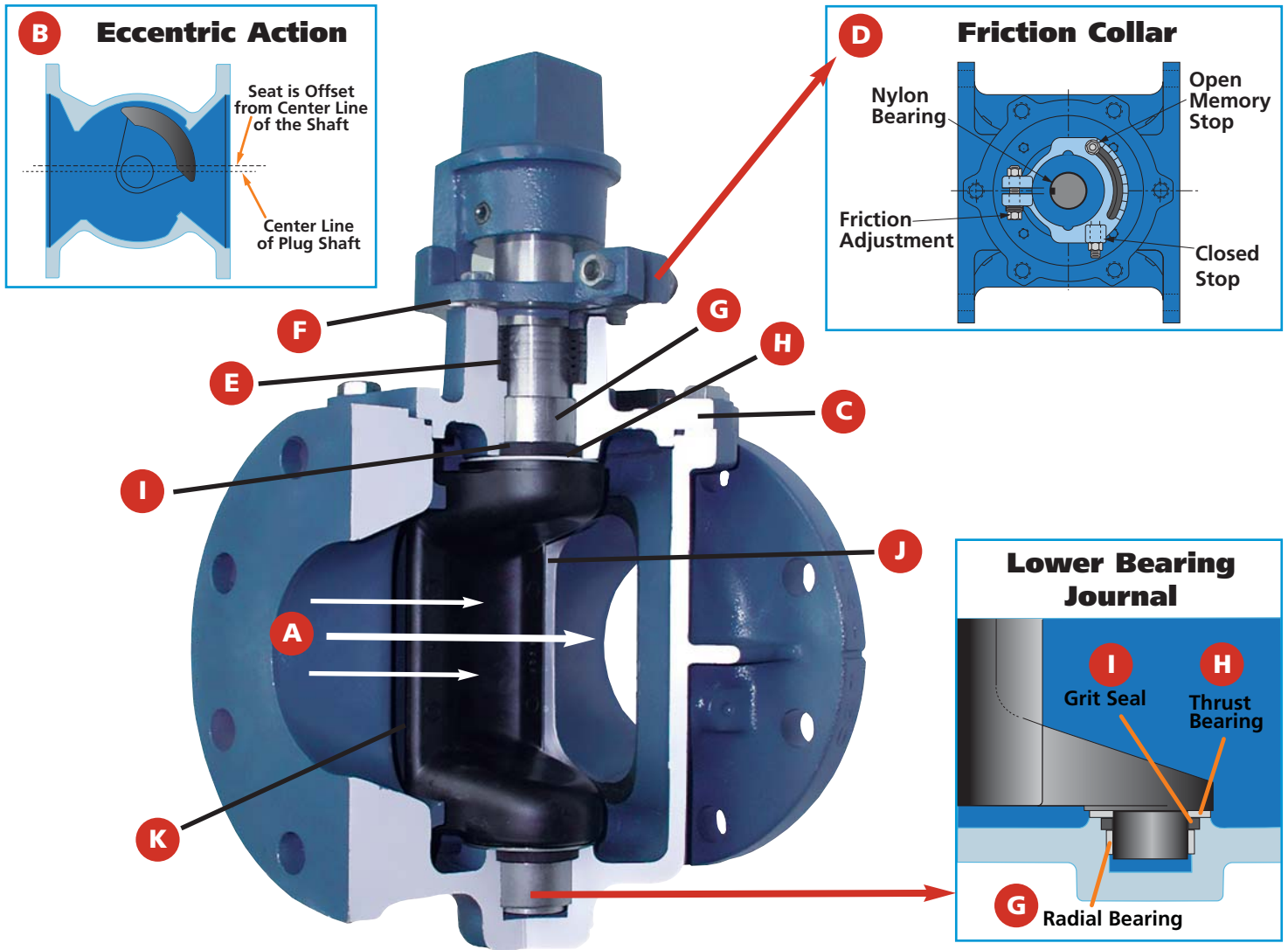

A. Non-Clog Design

The flow area and smooth streamline contouring allows passage of large solids to prevent potential clogging and provide low headloss.

B. Eccentric Action

Provides positive shut off in both directions with wear resistant action and low torque.

C. Full Top Access Cover

Provides accessibility for inspection without removal of the valve from the line.

D. Friction Collar with Memory Stop

Secures valve plug in any position and includes a nylon bearing for ease of operation.

E. V-Type Packing

Field adjustable and replaceable without removal of worm gear or motor actuators.

F. Removable POP™ Shims

Packing Overload Protection Shims protect packing by preventing overload during field adjustment.

G. Radial Bearings

Heavy Duty, T316 Stainless Steel, Permanently Lubricated.

H. Thrust Bearing

Upper: PTFE - Provides ease of actuation during operating conditions.

Lower: Stainless Steel - Prevents wear to plug and Grit-Guard.

I. Grit-Guard™ Shaft Seal

The *Val-Matic Exclusive* Grit-Guard™ shaft seal extends packing and bearing life by reducing wear and infiltration of grit.

J. Seat

The robotic pulsed-arc welded 95% nickel raised seat is corrosion and wear resistant.

K. Plug

Fully rubber encapsulated molded plug eliminates exposed surfaces for maximum resistance to corrosion and wear.

Proven Design

With installations worldwide, the Val-Matic Cam-Centric® Plug Valve has proven itself as the preferred valve for wastewater, industrial waste and process applications. The Cam-Centric® Plug Valve is a ¼ turn eccentric plug valve allowing cost effective, low torque actuation for pump control, shut-off and throttling service. The valve's eccentric action rotates the plug in and out of the seated position with minimal contact, thereby preventing high torque and wear to the valve seat and plug. The combination of the eccentric action, stainless steel bearings, Grit-Guard™ seals and heavy duty nickel seat assures long life with minimal maintenance.

Preferred Features

The Cam-Centric® Plug Valve features a shaft sealing system that utilizes V-Type packing, a packing follower and a Grit-Guard™ seal for ease of maintenance and to reduce wear. The Grit-Guard™ seals reduce wear by preventing grit and media from reaching the bearings and packing to prevent plug lock up. The seals are standard in both the upper and lower journals (Figures 1 & 2). To prevent the packing from being over tightened, the shaft seal incorporates POP™ (Packing Overload Protection) Shims. The packing is easily adjusted by removing the POP™ shims as necessary utilizing the pull tab feature (Figure 1). Adjustment or replacement of the V-Type packing can be done without removal of the gear, motor or cylinder actuator.

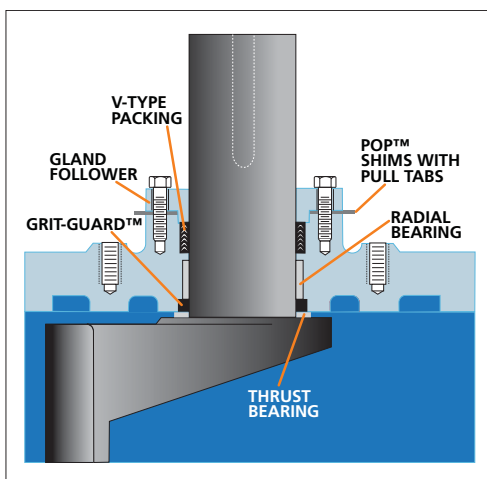

Figure 1. Upper Bearing Journal

The Cam-Centric® bearing package consists of permanently lubricated, T316 stainless steel radial bearings in both the upper and lower journals. The upper thrust bearing is made of PTFE and the lower thrust bearing is T316 stainless steel.

The Cam-Centric® Plug Valve utilizes a contoured and totally encapsulated molded plug to reduce corrosion and wear in severe abrasive applications. Its ductile iron construction provides strength and rigidity to withstand dynamic forces from flow and pressure.

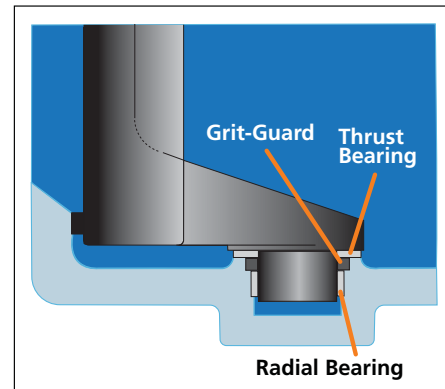

Figure 2. Lower Bearing Journal

The valve seat is a welded overlay of 95% pure nickel applied directly to the body on a machined surface using a state-of-the-art robotic welding system for a consistent, high quality weld (Figure 3).



Figure 3. Robotic welding of nickel seat

Advanced Technology

Incorporating the latest in valve technology assures a high-quality valve that will provide long service. The design process utilized solid Modeling and Finite Element Analysis (FEA) of the key structural components. Flow and torque data was derived from flow tests, mathematical models and Computational Fluid Dynamics (CFD). Manufacturing technology uses automated process control in the foundry and ISO 9001 controlled manufacturing processes. Every valve is tested in accordance with AWWA C517 and MSS SP-108 on automated hydraulic test rigs with gauges calibrated per ISO standards.

Actuation

The Cam-Centric® Plug Valve is available with a wide range of actuation options, from simple lever operation to advanced pump control systems. Options include 2" operator nuts, worm gears, chainwheels, electric motor and cylinder actuation. A wide variety of accessories such as floor stands and extended bonnets

are also available (see accessories on page 7). Val-Matic Engineering personnel work closely with cylinder and electric actuation manufacturers to assure actuator/valve compatibility. This ensures the actuator you specify will deliver the performance you expect when utilized with a Cam-Centric® Plug Valve.



Direct Nut operated valve with memory stop:

- Adjustable open memory stop for system balancing
- Adjustable close stop
- Adjustable friction collar
- For use with lever accessories



Val-Matic Worm Gears:

- Heavy Duty, totally enclosed and sealed
- For above ground and buried service applications
- Bronze radial bearings and roller thrust bearings provide smooth operations and extended life

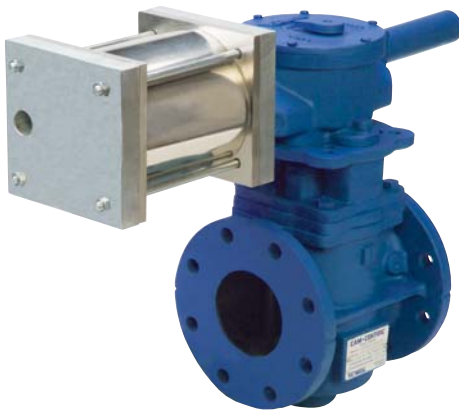

Val-Matic Cylinder Actuation:

- Compliance with AWWA C541 for Power Actuation
- Pneumatic/Hydraulic
- Single Acting or Double Acting
- Fail Open/Closed for power failure
- Modulating Service
- Throttling Service
- Limit Switches, Solenoid Valves, Positioners
- Manual Overrides
- Pump Control



Electric Actuation:

- 110 Single Phase, 230/460 Three Phase
- Compliance with AWWA C542 for Power Actuation
- Modulating Service
- Throttling Service
- Remote push button control and indication
- Torque Switches, Limit Switches
- De-clutchable handwheels
- Available from a wide variety of manufacturers

Worm Gear Features

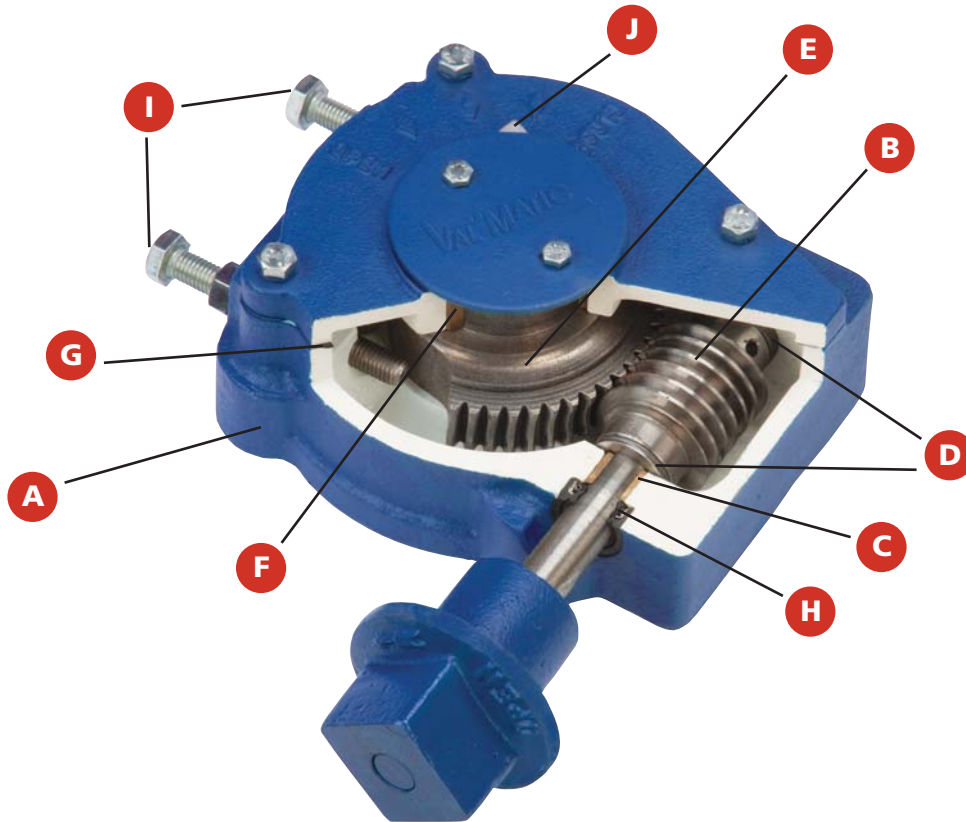

Val-Matic Worm Gear

A valve actuator must perform to the same level as the valve. The Val-Matic worm gear is designed and built to provide the same long term service as our Cam-Centric® Plug Valve. The exclusive bearing package in the worm gear includes four bronze sleeve bearings and two roller thrust bearings. This exclusive package assures smooth operation and long life regardless of the valve's orientation or application. The ductile iron segment gear coupled with the upper and lower bronze radial bearings exceed the requirements of AWWA C517 for strength and durability. All worm gears are designed to exceed, a rim pull of 200 pounds on handwheels and input torques of 300 foot pounds for operator nuts without damage. Buried service worm gears are grease packed, sealed and include stainless steel shafts. Worm gears can be provided with handwheels, chainwheels or 2" operator nuts.

A. Housing

Heavy duty, totally enclosed and sealed.

B. Worm

Hardened steel for durability and long life.

C. Radial Shaft Bearings

Bronze shaft bearings extend life and provide ease of operation (rear shaft bearing not visible).

D. Roller Thrust Bearings

Provides smooth operation and extends life.

E. Segment Gear

Heavy duty ductile iron for high strength. Provided with precision bore and keyway for connection to the valve shaft in multiple positions.

F. Segment Gear Radial Bearings

Upper and lower bronze bearings provide ease of operation and extend life (lower bearing not visible).

G. Cover Gasket

Seals housing and prevents foreign material or moisture from entering actuator and prevents loss of grease.

H. Shaft Seal

Prevents foreign material from entering the actuator.

I. External Stops

Both open and closed stops are external and easily adjustable.

J. Position Indicator

Displays precise plug position on above ground service.

Headloss Charts

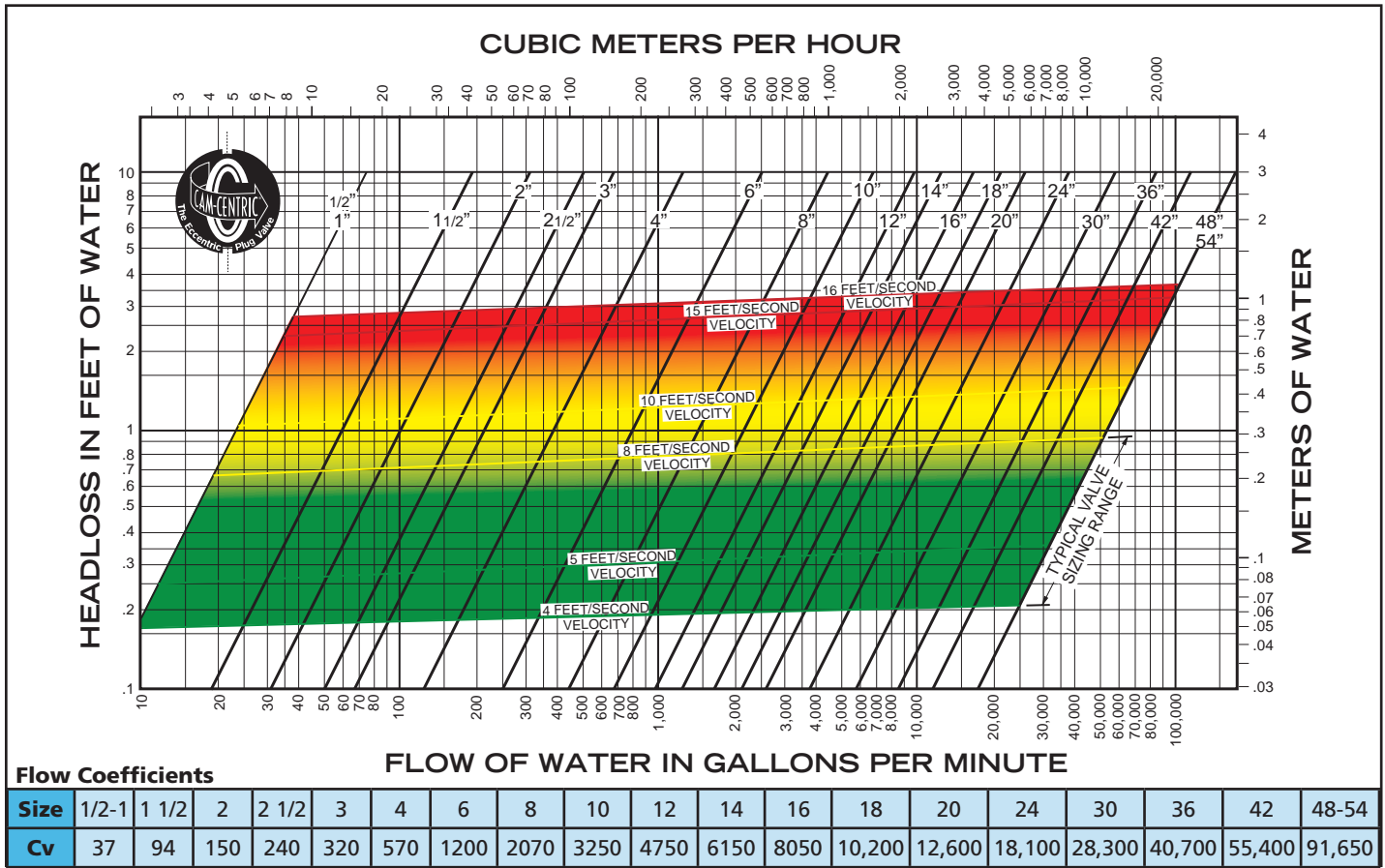

Installation Instructions

The installation of the valve is important for its proper operation. The valve is capable of flow in either direction but the maximum operating pressure can vary with the location of the seat end (Figure 5). The words "SEAT END" are marked on the valve flange.

SUSPENDED SOLIDS SERVICE: For fluids containing suspended solids, special orientations are needed to prevent debris from collecting in the valve. For horizontal installations (Figure 6), the valve should be installed with the flow entering the seat end of the valve and the shaft in a horizontal position with the plug up when open. For vertical installations (Figure 7), the valve must be installed with the seat end up regardless of flow direction.

CLEAN SERVICE: For both horizontal and vertical installations, install in the direct pressure orientation (pressure opposite the seat end).

AIR AND GAS SERVICE: Install valve in the direct pressure orientation (pressure opposite the seat end). Lubricate plug face with FDA approved silicone grease such as Dow Corning #7 before installation. Gear actuators are required for gas service applications.

PUMP DISCHARGE SERVICE: On all horizontal pump discharge applications, the seat end should be towards the pump.

BURIED SERVICE: Gear actuators are recommended for buried valves to hold the valve in position and provide multi-turn closure to prevent water hammer. The valve should be installed with the shaft horizontal and the actuator nut directed upwards. The valve box or extension pipe should be installed so that the actuator nut and extension stem turn freely.

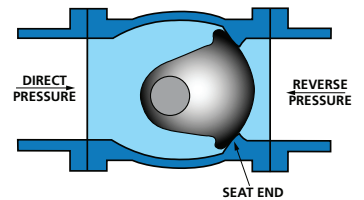

Figure 5. Installation Orientation

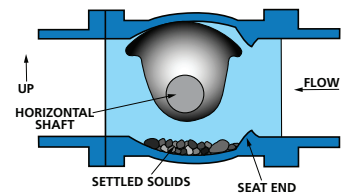

Figure 6. Horizontal Pipe w/ Solids

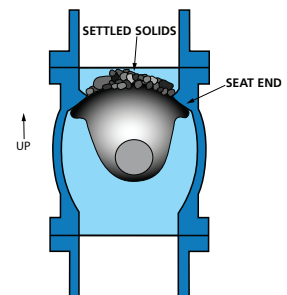

Figure 7. Vertical Pipe with Solids

Ratings/Construction

PRESSURE RATINGS

MAXIMUM PRESSURE RATINGS			
SERIES	CONNECTION	SIZE RANGE	CWP (psig)
5800RTL	ASME NPT Threaded	1/2" - 2"	175
5800R	ANSI Class 125 Flanged	2" - 12"	175
		14" - 54"	150
5800HP	ANSI Class 125 Flanged High Pressure	3" - 24"	250
5900R	AWWA C111 Mechanical Joint	3" - 12"	175
		14" - 48"	150
5900HP	AWWA C111 Mechanical Joint High Pressure	3" - 24"	250

MATERIALS OF CONSTRUCTION

COMPONENT	STANDARD
Body (5800R, 5900R)	Cast Iron ASTM A126, Class B
Body (5800HP, 5900HP)	Ductile Iron ASTM A536, Grade 65-45-12
Plug (5800R, 5900R)	Cast Iron ASTM A126, Class B, Buna-N Encapsulated, ASTM D2000
Plug (5800HP, 5900HP)	Ductile Iron ASTM A536, Grade 65-45-12, Buna-N Encapsulated, ASTM D2000
Radial Shaft Bearings	T316 Stainless Steel
Top Thrust Bearing	PTFE
Bottom Thrust Bearing	T316 Stainless Steel
Available Coatings	Two-Part Epoxy, Fusion Bonded Epoxy, Glass Lining, Rubber Lining

Accessories

Space limitations and application specifics often require special accessories. In addition to those shown below, Val-Matic offers a wide range of accessories to meet your application requirements.

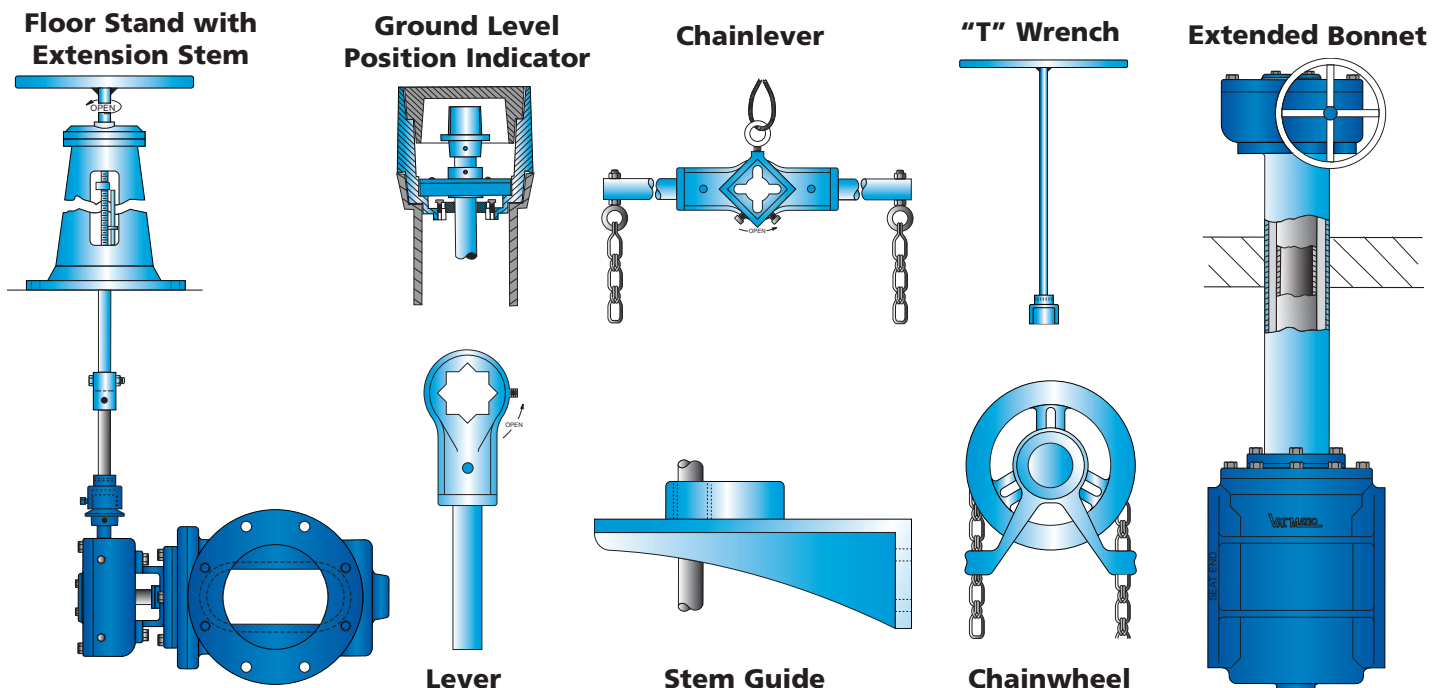

Installation Dimensions

Direct Nut Operated

Flanged, Mechanical Joint, Threaded End Connections

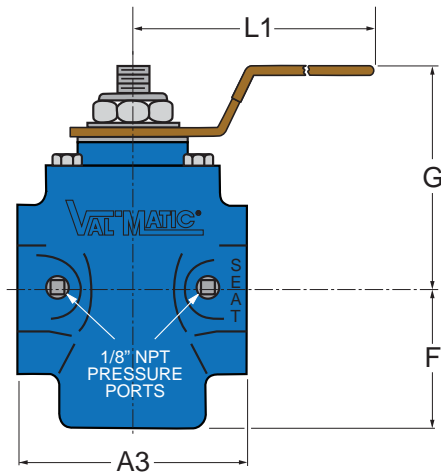

Sizes 1/2" - 2"

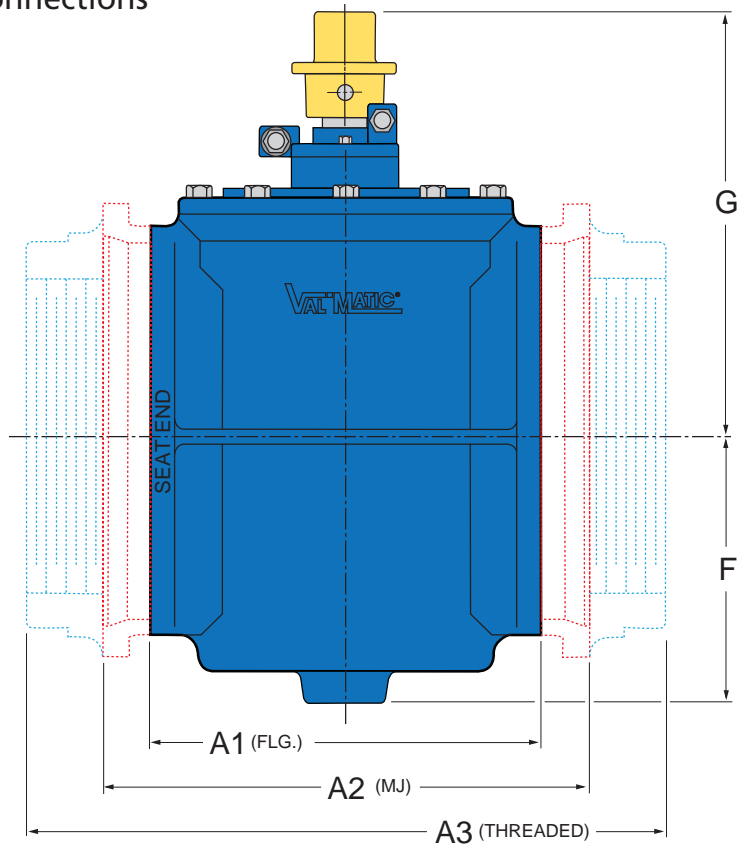

Sizes 2" - 8"

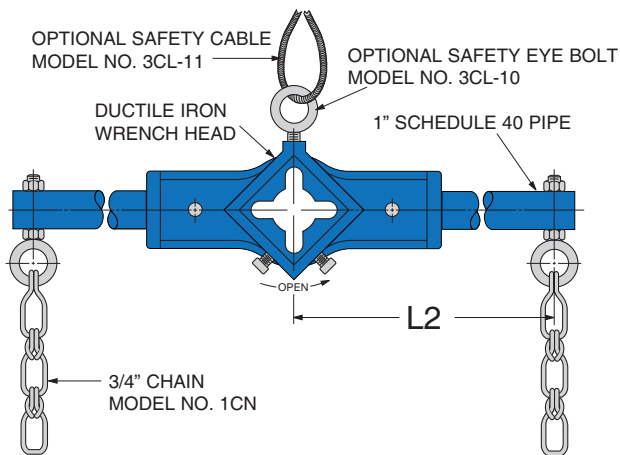

Chainlever

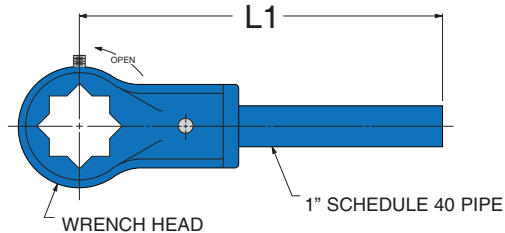

Handlever

Dimensions in Inches

Valve Size	Flanged Model No.	MJ Model No.	Threaded Model No.	Handlever Model No.	Chainlever Model No.	Reverse	Direct	A1	A2	A3	F	G	L1	L2
1/2	-	-	5800.5RTL	Std	-	175	175			4.13*	1.88	3.19	4.25	-
3/4	-	-	5800.75RTL	Std	-	175	175			4.13*	1.88	3.19	4.25	-
1	-	-	5801RTL	Std	-	175	175	-	-	3.13	1.88	3.19	4.25	-
1 1/4	-	-	5801.25RTL	Std	-	175	175			6.75*	2.88	4.25	6.50	-
1 1/2	-	-	5801.5RTL	Std	-	175	175			6.75*	2.88	4.25	6.50	-
2	5802RN	-	5802RTL	Std	-	175	175	7.50	-	5.25	2.88	4.25	6.50	-
2 1/2	5825RN	-	5825RTN	4L	3CL	175	175	7.50	-	8.75	4.63	10.00	22.00	16.00
3	5803RN	5903RN	5803RTN	4L	3CL	175	175	8.00	11.50	8.75	4.63	10.00	22.00	16.00
4	5804RN	5904RN	-	4L	4CL	175	175	9.00	14.25	-	5.56	10.93	22.00	22.00
6	5806RN	5906RN	-	8L	6CL	50	100	10.50	15.75	-	7.06	12.31	44.00	32.00
8	5808RN	5908RN	-	8L	8CL	50	100	11.50	17.25	-	8.75	13.88	44.00	44.00

*Asterisk indicates length includes reducing bushing.

Notes: 1. Flange drilling conforms to ANSI B16.1, Class 125.

2. Mechanical Joint (MJ) Ends conform to ANSI/AWWA C110/A21.10.

3. Threaded Ends conform to ANSI/ASME B1.20.1.

4. Handlevers (i.e. 4L) Chainlevers (i.e. 3CL) and Chain (1CN) are ordered separately.

Installation Dimensions

Series 5800R & 5800HP Flanged

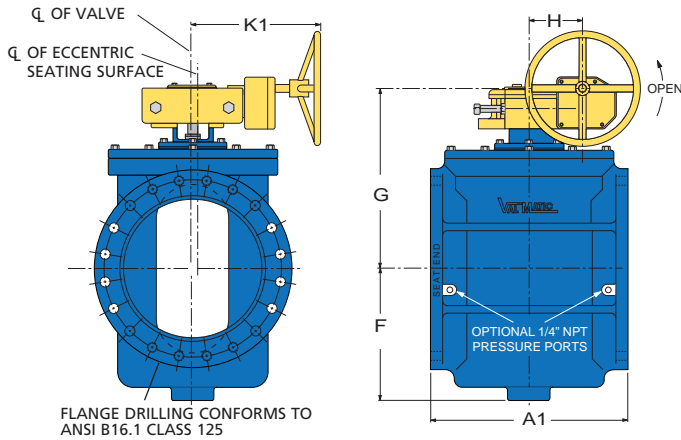

FLANGE DRILLING CONFORMS TO ANSI B16.1 CLASS 125

Series 5900R & 5900HP Mechanical Joint

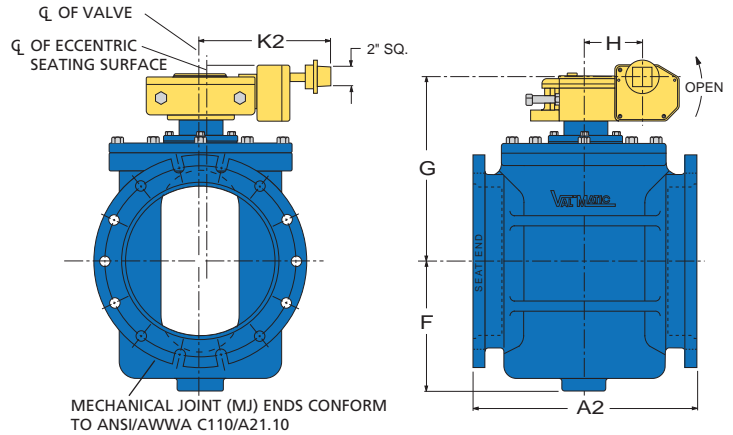

MECHANICAL JOINT (MJ) ENDS CONFORM TO ANSI/AWWA C110/A21.10

Dimensions in Inches

Valve Size	Flanged Model No.	MJ Model No.	Reverse	Direct	A1	A2	F	G	H	K1	K2
2 1/2	5825R/7A08*	-	175	175	7.50	-	4.50	7.50	3.06	9.50	-
3	5803R/7A08*	5903R/8A02A*	175	175	8.00	11.50	4.50	7.50	3.06	9.50	9.00
	5803HP/7A08*	5903HP/8A02A*	250	250							
4	5804R/7A08*	5904R/8A02*	175	175	9.00	14.25	5.56	9.31	3.06	9.50	9.00
	5804HP/7A08*	5904HP/8A02*	250	250							
6	5806R/7A08*	5906R/8A02*	175	175	10.50	15.75	7.06	11.06	3.06	9.50	9.00
	5806HP/7A12*	5906HP/8A02*	250	250							
8	5808R/7A12*	-	100	175	11.50	17.25	8.75	12.62	3.06	11.50	9.00
	5808R/7B16*	5908R/8A02*	175	175							
	5808HP/7B18*	5908HP/8A02*	250	250							
10	5810R/7C12*	5910R/8C02*	100	175	13.00	18.75	10.44	16.25	4.75	13.13	7.88
	5810R/7D16*	5910R/8D02*	175	175							
	5810HP/7D16*	5910HP/8D02*	250	250							
12	5812R/7C16*	5912R/8C02*	100	175	14.00	19.75	12.50	17.69	4.75	11.00	7.88
	5812R/7D24*	5912R/8D02*	175	175							
	5812HP/7D24*	5912HP/8D02*	250	250							
14	5814R/7E18*	-	50	100	17.00	24.50	13.00	19.31	5.62	15.25	13.00
	5814R/7G12	5914R/8F02*	150	150							
	5814HP/7G12	5914HP/8F02*	250	250							
16	5816R/7E24*	-	50	100	17.75	24.75	14.50	20.62	5.62	17.12	13.00
	5816R/7G14	5916R/8F02*	150	150							
	5816HP/7G18	5916HP/8F02*	250	250							
18	5818R/7J30*	-	50	100	21.50	28.50	16.25	22.25	5.62	18.62	14.50
	5818R/7L24	5918R/8K02	150	150							
	5818HP/7L24	5918HP/8K02	250	250							
20	5820R/7M18	-	50	100	23.50	30.50	17.50	26.25	7.38	19.00	14.50
	5820R/7P30	5920R/8K02.5	150	150							
	5820HP/7P30	5920HP/8K02.5	250	250							
24	5824R/7M24	-	50	100	30.00	37.00	20.25	29.00	7.38	19.25	14.50
	5824R/7Q36	5924R/8K02.5	150	150							
	5824HP/7Q36	5924HP/8K02.5	250	250							
30	5830R/7R24	-	50	100	37.50	45.50	24.00	31.00	4.06	16.12	14.44
	5830R/7T30	5930R/8S02	150	150							
36	5836R/7S30	-	50	100	52.00	60.00	29.00	31.00	4.06	16.12	14.44
	5836R/7W36	5936R/8T02	150	150							
42	5842R/7X30	-	50	100	62.00	70.00	36.50	44.00	14.00	25.25	27.60
	5842R/7Z36	5942R/8Z02	150	150							
48	5848R/7X30	-	50	100	84.00	84.00	38.50	48.46	10.90	27.60	27.60
	5848R/7Z36	5948R/8Z02	150	150							
54	5854R/7X30	-	50	100	96.00	-	38.50	48.46	10.90	27.60	-
	5854R/7Z36	-	150	150							

*Asterisk indicates valve model numbers without spur gear

Notes: 1. Replace Handwheel (HW) diameter in the model number (i.e. /7A08) with 02 for 2" square operating nut (i.e./7A02).

2. Add a C suffix to model number to include Chainwheel Kit (i.e. 5804R/7A08C).

3. Available with ISO/PN drilling.

4. Consult factory for larger sizes.

Flow Characteristics

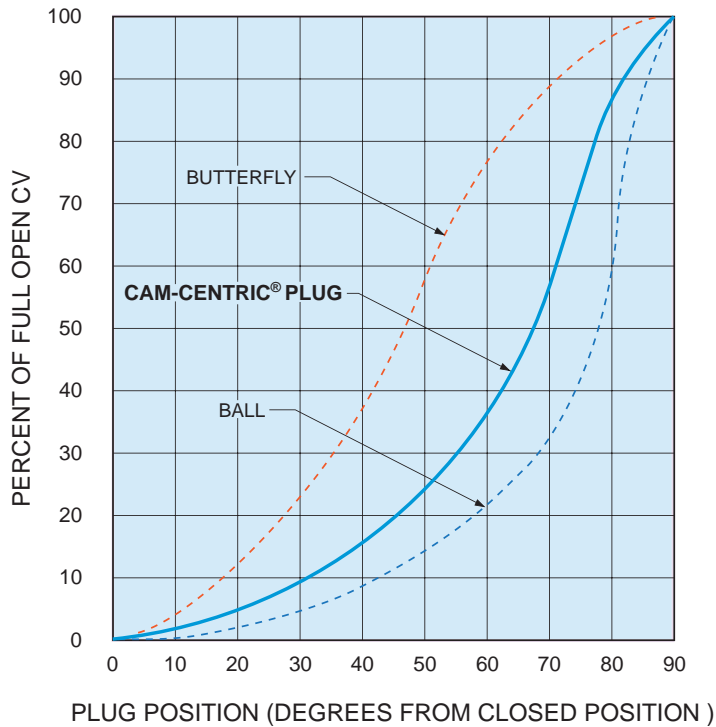

INHERENT PUMP CONTROL FLOW CHARACTERISTICS

To control pressure surges and provide good-controllability, the flow characteristics of valves should be considered.

The graph at left shows the inherent flow characteristics at a constant ΔP for various valves.

The Plug Valve has an inherent flow characteristic similar to a ball valve. When installed in a pipeline, the plug valve will approximate a linear flow characteristic because the piping system pressure losses will shift the flow curve to the left. A linear installed flow characteristic will help control surges and provide a wide range of controllability.

Installations



Cam-Centric® Plug Valve with worm gear actuator and chainwheel



Cam-Centric® Plug Valve with Val-Matic Swing-Flex®



Cam-Centric® Plug Valve with Val-Matic dual body combination Air Valve



Cam-Centric® Plug Valve with motor actuator



Cam-Centric® Plug Valve with worm gear actuator



Cam-Centric® Plug Valve with worm gear actuator and extension stem

2-Way Specification

SCOPE

- 1.1 This specification covers the design, manufacture, and testing of 1/2 in. (15 mm) through 3 in. (80 mm) Threaded Eccentric Plug Valve, 2 1/2 in. (60 mm) through 54 in. (1350 mm) Eccentric Plug Valve suitable for water or wastewater service with pressures up to 250 psig (1725 kPa).
- 1.2 Plug Valves shall be quarter-turn, non-lubricated with resilient encapsulated plug.

STANDARDS AND APPROVALS

- 2.1 2 1/2 in. (60 mm) through 54 in. (1350 mm) plug valves shall be designed, manufactured and tested in accordance with American Water Works Association Standard ANSI/AWWA C517.
- 2.2 All Plug Valves shall be certified Lead-Free in accordance with NSF/ANSI 372.
- 2.3 Manufacturer shall have a quality management system that is certified to ISO 9001 by an accredited, certifying body.

CONNECTIONS

- 3.1 Threaded valves shall have threaded NPT full size inlets. The connection shall be hexagonal for a wrench connection.
- 3.2 Flanged valves shall have flanges with drilling to ANSIB16.1, Class 125.
- 3.3 Mechanical Joint valves shall fully comply with ANSI/AWWA C111/A21.11.

DESIGN

- 4.1 Threaded and all other valves under 4" (100mm) shall have port areas of not less than 100% of pipe area. Port areas on other sizes are 85% on 16" (400 mm) and smaller, 80% on 18"-24" (150 mm- 600 mm), and 75% on 30" (800 mm) and larger.
- 4.2 Threaded valve seat shall be a machined seating surface.
- 4.3 2 1/2 in. (60 mm) through 54 in. (1350 mm) plug valves shall have a valve seat that is a welded overlay of 95% pure nickel applied directly to the body on a pre-machined, cast seating surface and machined to a smooth finish.
- 4.4 Threaded valves shall have shaft seals which consist of V-type lip seal in a fixed gland with a resilient O-ring spring.
- 4.5 2 1/2 in. (60 mm) through 54 in. (1350 mm) plug valves shall have shaft seals which consist of V-type packing in a fixed gland with an adjustable follower designed to prevent over compression of the packing and to meet design parameter of the packing manufacturer. Removable POP™ shims shall be provided under the follower flanges to provide for adjustment and prevent over tightening.
- 4.6 Permanently lubricated, radial shaft bearings shall be supplied in the upper and lower bearing journals. Thrust bearings shall be provided in the upper and lower journal areas, except for threaded type which only have upper thrust bearings.
- 4.7 Both the packing and bearings in the upper and lower journals shall be protected by a Grit-Guard™ "drip tight" Buna-N shaft seal located on the valve shaft to minimize the entrance of grit into the bearing journal and shaft seal areas.
- 4.8 The threaded valve body shall have 1/8" NPT upstream and downstream pressure ports.

MATERIALS

- 5.1 Valve bodies and covers shall be constructed of ASTM A126 Class B cast iron for working pressures up to 175 psig (1200 kPa) and ASTM A536 Grade 65-45-12 for working pressures up to 250 psig (1725 kPa). The words "SEAT END" shall be cast on the exterior of the body seat end.
- 5.2 Threaded valve plugs in sizes 1/2 in. (15 mm) through 3 in. (80 mm) shall be of one-piece construction and made of ASTM A126 Class B cast iron fully encapsulated with a resilient facing per ASTM D2000-BG and ANSI/AWWA C517 requirements.

- 5.3 2 1/2 in. (60 mm) through 54 in. (1350 mm) plugs shall be of one-piece construction and made of ASTM A126 Class B cast iron or ASTM A536 Grade 65-45-12 ductile iron and fully encapsulated with resilient facing per ASTM D2000-BG and ANSI/AWWA C517 requirements.
- 5.4 Threaded valves shall have radial shaft bearings constructed of self-lubricating Type 316 stainless steel. The top thrust bearing shall be PTFE.
- 5.5 2 1/2 in. (60 mm) through 54 in. (1350 mm) plug valves shall have radial shaft bearings constructed of self-lubricating Type 316 stainless steel. The top thrust bearing shall be PTFE. The bottom thrust bearing shall be self-lubricating Type 316 stainless steel. Cover bolts shall be corrosion resistant with zinc plating.

ACTUATION

- 6.1 Threaded valves shall be equipped with a hand lever with a dial indicator and open memory stop.
- 6.2 Valves 2 1/2 in. (60 mm) to 8 in. (200 mm) and 4 in. (100mm) to 6 in. (150 mm) 100% ported shall be equipped with a 2 inch square nut for direct quarter turn operation. The packing gland shall include a friction collar and an open position memory stop. The friction collar shall include a nylon sleeve to provide friction without exerting pressure on the valve packing.
- 6.3 When specified valves 4 in. (100 mm) and larger shall include a totally enclosed and sealed worm gear actuator with position indicator (above ground service only) and externally adjustable open and closed stops. The worm segment gear shall be ASTM A536 Grade 65-45-12 ductile iron with a precision bore and keyway for connection to the valve shaft. Bronze radial bearings shall be provided for the segment gear and worm shaft. Alloy steel roller thrust bearings shall be provided for the hardened worm.
- 6.4 All gear actuators shall be designed to withstand, without damage, a rim pull of 200 lb. on the hand wheel and an input torque or 300 ft-lbs. for nuts.
- 6.5 Buried service actuators shall be packed with grease and sealed for temporary submergence to 20 feet of water. Exposed worm shafts shall be stainless steel.

OPTIONS

- 7.1 When specified, the valve port area shall have not less than 100% of pipe area.
- 7.2 The interior and exterior of the valve shall be coated with an NSF/ANSI 61 approved fusion bonded epoxy.
- 7.3 The interior of the valve shall be coated with 8 mils SG-14 glass lining or 1/8" soft rubber lining.

MANUFACTURE

- 8.1 Manufacturer shall demonstrate a minimum of ten (10) years' experience in the manufacture of plug valves. When requested, the manufacturer shall provide test certificates, dimensional drawings, parts list drawings and operation and maintenance manuals.
- 8.2 The exterior of the valve for above ground service shall be coated with a universal alkyd primer. Valve exterior for buried service shall be coated with an epoxy coating.
- 8.3 Valve shall be marked with the Serial Number, Manufacturer, Size, Cold Working Pressure (CWP) and the Direct and Reverse Actuator Pressure Ratings on a corrosion resistant nameplate.
- 8.4 Plug Valves shall be Series # 5800RTL (Threaded), 5800R (Flanged), 5800HP (Flanged), 5900R (Mechanical Joint) or 5900HP (Mechanical Joint) as manufactured by Val-Matic Valve and Mfg. Corporation, Elmhurst, IL. USA or approved equal.



Val-Matic's quality of design and meticulous workmanship has set the standards by which all others are measured. Quality design features such as the AWWA **Ener-G® Ball Valve** with its energy efficient design, fusion bonded epoxy and adjustable resilient seating....**Cam-Centric® Plug Valves** have more requested features than any other eccentric plug valve....**American-BFV® Butterfly Valves** include a field replaceable seat without the need for special tools....**Tilted Disc® Check Valves** with high strength and wear resistant aluminum bronze trim as standard....**Silent Check Valves** featuring combined resilient/metal-to-metal seating and are **NSF/ANSI 61 & 372 Certified**....**Sure Seal Foot Valves** provided with a heavy duty stainless steel screened inlet....**Swing-Flex® and Surgebuster® Check Valves** designed with an unrestricted full flow area....**Swing Check Valves** with field adjustable closure

versatility....**Dual Disc® Check Valves** utilizing stabilized components to provide extended life....**Air Release, Air/Vacuum and Combination Air Valves** provided standard with Type 316 stainless steel trim....**VaultSafe®** family of products includes the **FloodSafe® Inflow Preventer**, **FrostSafe®** two-way damper and the **VentSafe®** vent pipe security cage. The **QuadroSphere® Trunnion Ball Valve** features a unique ball design with recessed surfaces creating additional flow paths to provide a self-cleaning action and reduced wear and torque.

Val-Matic is totally committed to providing the highest quality valves and outstanding service to our customers. Complete customer satisfaction is our goal. **Make the change to quality, specify Val-Matic!**



Val-Matic Valve and Manufacturing Corp.
 905 Riverside Drive, Elmhurst, IL 60126
 Phone: 630-941-7600 • Fax: 630-941-8042
 www.valmatic.com • valves@valmatic.com

Copyright © 2017 Val-Matic Valve & Mfg. Corp.
 ISO 9001:2008 certified company 10/17